

Installation and Operating Instructions

JUDO BIOSTAT-COMBIMAT

Water Treatment Device

Model BST-CA

Valid for: Canada

Attention:

Carefully read through the installation and operating instructions and safety information before installing and putting the unit into service.

These Instructions must always be issued to the owner/user.

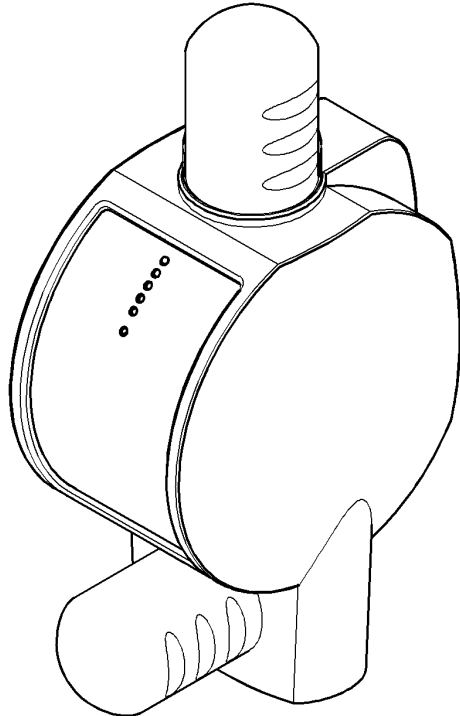

BST-CA



Co-orporate Head Office

JUDO Wasseraufbereitung GmbH
P.O. Box 380
D-71351 Winnenden
Germany

internet: <http://www.judo.eu>

e-mail: info@judo.eu

Manufacturing

JUDO Wasseraufbereitung GmbH
Hohreuschstraße 39-41
D-71364 Winnenden
Germany

Dear Customer,

Thank you for the confidence you have shown in us by purchasing this unit. With this water treatment device you have purchased an unit that corresponds fully to the most up-dated standards of technology.

This water treatment device is suitable for use in cold drinking water up to a maximum ambient temperature of 86 °F (30 °C).

Each unit is thoroughly checked before delivery. Should difficulties occur, please contact the responsible customer service. See back page.

Trademarks:

Trademarks used in this document are protected and registered trademarks of the respective holder.

© JUDO Wasseraufbereitung GmbH
D-71364 Winnenden

All rights reserved.

Reprints – even of extracts – is only permitted with special written approval.

Federal Communication Commission Interference Statement

This equipment has been tested and found to comply with the limits for a Class B digital device, pursuant to Part 15 of the FCC Rules. These limits are designed to provide reasonable protection against harmful interference in a residential installation. This equipment generates, uses and can radiate radio frequency energy and, if not installed and used in accordance with the instructions, may cause harmful interference to radio communications. However, there is no guarantee that interference will not occur in a particular installation. If this equipment does cause harmful interference to radio or television reception, which can be determined by turning the equipment off and on, the user is encouraged to try to correct the interference by one or more of the following measures:

- Reorient or relocate the receiving antenna.
- Increase the separation between the equipment and receiver.
- Connect the equipment into an outlet on a circuit different from that to which the receiver is connected.
- Consult the dealer or an experienced radio / TV technician for help.

FCC Caution: To assure continued compliance, any changes or modifications not expressly approved by the party responsible for compliance could void the user's authority to operate the equipment.

This device complies with Part 15 of the FCC Rules. Operation is subject to the following two conditions: (1) this device may not cause harmful interference, and (2) this device must accept any interference received, including interference that may cause undesired operation.

Table of Contents

1. About this Operating Instructions ...	5	7. Maintenance.....	22
1.1 Symbols used	5	7.1 Cleaning	22
1.2 Safety information and dangers due to non-compliance	6	8. Warranty and Services.....	22
1.3 Units used.....	6	9. Data Sheet.....	23
2. Intended Use	7	9.1 Type	23
2.1 Water pressure	8	9.2 Models.....	23
2.2 Notes on special dangers	8	9.3 Technical specifications	23
3. Product Information	9	9.4 Mounting Dimensions	24
3.1 Intended purpose.....	9	9.5 Scope of supply.....	24
3.2 Materials used	9	9.6 Accessories	24
4. Installation	9	10. Spare Parts BIostat-COMBIMAT.	25
4.1 General.....	9	11. Customer Service.....	28
4.2 Requirements for the place of installation.....	10		
4.3 Discharging the flushing water ..	12		
5. Operation	14		
5.1 Commissioning	14		
5.2 Description of its function	15		
5.3 Control lamps, manual pushbuttons	17		
5.4 Cleaning - Flushing.....	18		
5.5 Warning message "Battery low" ..	18		
5.6 Mounting of the panelling	18		
5.7 Replacing the batteries.....	18		
5.8 Modifications / changes / spare parts.....	19		
5.9 Stoppages	20		
6. Fault.....	21		

Unit-No.:

.....

1. About this Operating Instructions



(see chapter “Safety information and dangers due to non-compliance”)

This users’ manual should always be kept near the actual device in operation.

This instruction manual is intended to make it easier to familiarize yourself with the water treatment device and its possible intended uses.

The instruction manual contains important information required for the safe, correct and economical use of the unit concerned.

It contains fundamental information, which must be observed during installation, operation and maintenance. Observance of this information helps to avoid dangers, reduce repair costs and increase the reliability and working life of the water treatment unit.

The instruction manual must be read and used by each person entrusted with carrying out work on the water treatment device, for example:

- **Installation**
- **Operation**
- **Maintenance**
(servicing, inspection, repair)

Installation and maintenance may only be carried out by personnel authorized by the manufacturer, who are capable of fulfilling the instructions given in the installation and operating instructions and the country-specific prescriptions.

Apart from the instruction manual and the laws governing health & safety applicable in the country and place of use, the recognised technical regulations for safe and proper work must also be observed.

Therefore, this instruction manual must always be read by the fitter and responsible skilled personnel/owner or operator before installation, commissioning and maintenance.

Not only the general safety notes given in the chapter on “Intended Use” are to be observed, but also the special safety notes inserted under the other main items.

1.1 Symbols used

The safety notes contained in this instruction manual are labelled with the following symbols:

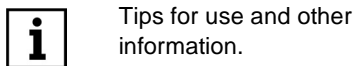
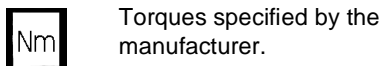
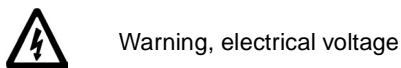

Notes directly attached to the water treatment device, e.g.:

- Direction of flow (see Fig. 1)
- Type plate
- Cleaning information

must always be observed and kept in a fully legible condition.

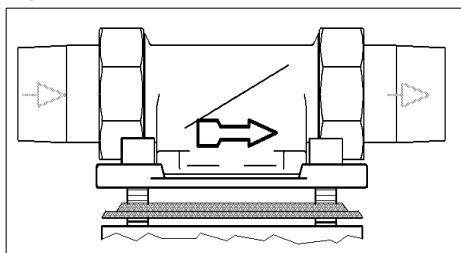

Fig. 1: Built-in rotary flange

1.2 Safety information and dangers due to non-compliance

Failure to observe the general danger symbols may result, for example, in the following risks:

- Failure of important functions of the water treatment device.
- Danger to persons due to electrical and mechanical effects.
- Danger to persons and the environment due to leaks.

Refrain from any unsafe working methods.

Failure to comply with this instruction manual and the safety information can not only result in dangers for people but can also harm the environment and the unit.

1.3 Units used

In derogation of the International System of Units (SI = System International), the following units are used:

Units	Conversion
°F	$^{\circ}\text{F} = 9/5 \text{ }^{\circ}\text{C} + 32$
psi	$\text{kPa} = 0.001 \text{ N/mm}^2$
gpm	$1 \text{ m}^3/\text{h} = 4.4 \text{ gpm}$
3/4"	DN 20
1"	DN 25
1 1/2"	DN 40

2. Intended Use

Installation and use of the water treatment devices are each subject to the applicable national regulations.

Apart from the instruction manual and the legally binding accident prevention provisions applicable in the country and place of use, the recognized technical regulations for safe and proper work must also be observed.

The water to be treated must possess quality of drinking water!

Always contact the manufacturer/supplier before using water with a different quality or with additives!

This water treatment devices is suitable for use in cold drinking water up to maximum ambient temperature of 86 °F (30 °C).

It is produced according to the newest standards of technology and the generally accepted safety regulations in Germany.

The water treatment devices may only be used as described in the instruction manual. Any other or further use is deemed not to be intended use.

Additional dangers exist in case of non-intended use and failure to observe the danger symbols and safety information. The manufacturer/supplier are not liable for any losses or damage resulting from this. The risk is solely borne by the user.

Intended use also includes observing the instruction manual.

The manufacturer/supplier must always be consulted before using the water treatment devices outside the use limitations given in the instruction manual.

The water treatment devices are only to be used in a technically perfect condition, for their intended use, safely and aware of the dangers and with full observance of the instruction manual!

Have any malfunctions corrected immediately!

In order to be able to discharge safely the wastewater in operation and in case of any defect in the system, precise compliance with the details stated in the chapter on "Requirements for the place of installation" is necessary!

Use is permitted in the whole field of drinking water, provided the water to be treated is not calcium-antagonistic.

2.1 Water pressure

The water pressure must be between 22 psi (150 kPa) and 116 psi (800 kPa).

If the water treatment device is not regularly regenerated, this can result in a pressure loss and impairment of the softening function.



(see chapter “Safety information and dangers due to non-compliance”)

If the **water pressure is more than 116 psi (800 kPa)** a pressure reducer must be installed **before** the water treatment device (see Fig. 2). An operating pressure of more than 116 psi (800 kPa) can lead to malfunction and failure.

The optimal operating pressure for the water treatment device lies between 44 psi (300 kPa) and 73 psi (500 kPa). It works most economically under these pressure conditions. In modern sanitary installations (in particular where single lever mixers are used), despite normal system pressure conditions, peak pressures of up to over 440 psi (3000 kPa) frequently occur. This can cause damage to important functional interior parts of the water treatment device.

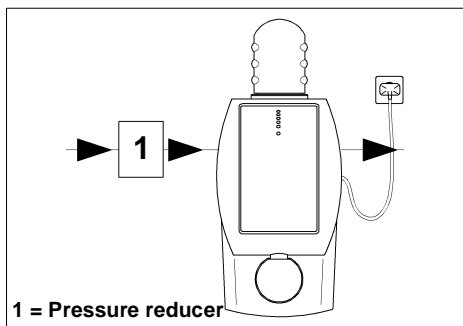

Fig. 2: Pressure reducer upstream of the water treatment device.



For a **water pressure of 73 psi (500 kPa) to 116 psi (800 kPa)** we recommend the installation of a pressure reducer.

2.2 Notes on special dangers

2.2.1 Electrical equipment / installations



There must not be any electrical cables and devices underneath or in the immediate vicinity of the water treatment device!

Electrical devices / equipment, which are not splash proof and which are located near the water treatment device can be damaged by water which escapes from the water treatment device during “Cleaning - Flushing” or improper use. If the electrical devices / installations are connected to the power supply, a short circuit can also occur. In this case there is a risk of people suffering an electric shock. Electrical devices / equipment located near the water treatment device must therefore be splash proof and comply with the legal regulations for wet rooms (IP44).

3. Product Information

3.1 Intended purpose

This water treatment device is suitable for use in cold drinking water up to a maximum water temperature of 86 °F (30 °C).



(see chapter “Safety information and dangers due to non-compliance”)

Please refer to the chapter on “Intended Use” for use restrictions.

This water treatment device reduces the tendency of the water to precipitate out excess calcium and thus protects the water-pipes and water heaters from lime deposits.

Appliances and taps are protected.



Lime deposits restrain the water flow and can therefore lead to an increased energy consumption.

3.2 Materials used

The used materials are resistant to the physical, chemical and corrosive properties to be expected in the drinking water. All materials are hygienically and physiologically safe. Plastics (KTW recommendations) and metallic materials fulfil the requirements of the BgVV (German Federal Institute for Consumer Health Protection and Veterinary Medicine).

4. Installation

4.1 General



(see chapter “Safety information and dangers due to non-compliance”)

The unit may only be installed by skilled personnel.

The chapter on “Intended Use” has always to be observed !

The pipes must be able to support in a safe way the water treatment devices.

Otherwise mechanical damage or fractures/bursts can occur in the pipes. This can result in major water damage. People close to the water treatment device are exposed to a health risk due to the large quantities of water released. Therefore, if necessary, the pipes must be additionally fixed or supported.

Always observe the given spacings to ensure convenient operation and servicing (see chapter “Mounting Dimensions”)

A distance of at least 6 Inch (150 mm) above and below the water treatment device is required in order to be able to carry out properly all the maintenance and servicing work.

When installing the water treatment devices in the feed-pipe to the water heater, ensure that the safety valve of the water heater is located **after** the water treatment device in the direction of flow.

4.2 Requirements for the place of installation

The room where the unit is installed must be dry and frost free!

Unauthorised persons must not have access to the water treatment device!



(see chapter "Safety information and dangers due to non-compliance")

- The ambient temperature must not exceed 86 °F (30 °C)! At higher temperatures or direct sun radiation the material can be damaged.
- We recommend that the water treatment devices is installed after a backwash protective filter, to prevent particles of dirt and sand being swept in.



A power connection (120 V, 60 Hz), which has to be permanently under voltage, must be available.

- Length of the power lead is approximately 60 Inch (1.5 m).
- Particularly in the case of small cross-sections and soft pipe materials, the water pipes should be supported in the vicinity of the connecting flange with two pipe-clamps.

4.2.1 Installed position



(see chapter "Safety information and dangers due to non-compliance")

Always install the water treatment devices in a vertical position ($\pm 5^\circ$)!

Unless, impairments of its function can occur.

4.2.2 Power supply



A splash proof socket is required for the power supply, in accordance with the legal regulations for wet rooms.



(see chapter "Safety information and dangers due to non-compliance")

A permanent power supply must be available. If the water treatment devices is not permanently supplied with power, there is no warning in case of faults, and no water is treated.

4.2.3 Mounting the built-in rotary flange

The built-in rotary flange is used as a connecting element between the pipe and the water treatment device.

It is suitable for both, -horizontally and vertically mounted pipes.

The built-in rotary flange must be installed in the direction of flow. This is marked by a cast in arrow (see Fig. 1).

If these instructions aren't respected, the water treatment device doesn't work.



ATTENTION

(see chapter "Safety information and dangers due to non-compliance")

The flange surface of the built-in rotary flange must be in a vertical position! The built-in rotary flange must be fitted thus that mechanical stresses cannot occur! Otherwise mechanical damages can arise at the built-in rotary flange. This can lead to major water damages.

In this case, people close to the water treatment devices are exposed to a health risk due to the large quantities of water.

Therefore, when mounting, ensure that no large forces act on the pipe, built-in rotary flange and water treatment devices.

4.2.4 Mounting of the Bypass Valve (accessories)

The flange of the bypass valve marked with the cast in letter "R" (pipe) is screwed onto the built-in rotary flange. The conditioner is fitted onto the flange marked with the cast in letter "G" (unit). The hand-wheel of the bypass valve can be positioned anywhere above the unit or to the side if there is enough space between the pipe and wall. Depending on conditions on site, installation

should be carried out ensuring sufficient access to the hand-wheel.

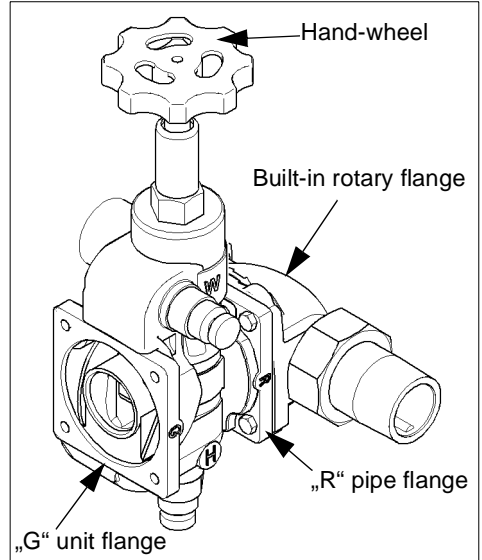

Fig. 3: Bypass valve

4.2.5 Fitting the wall support

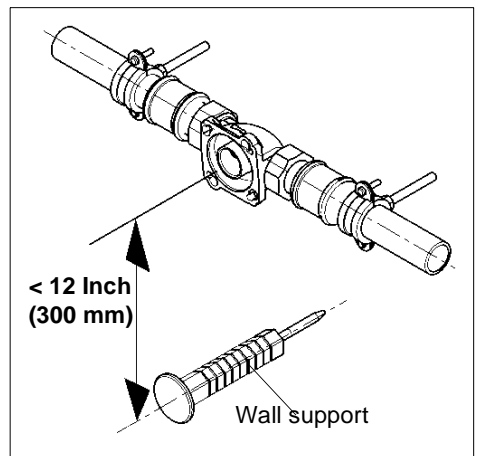

Fig. 4: Wall support without bypass valve

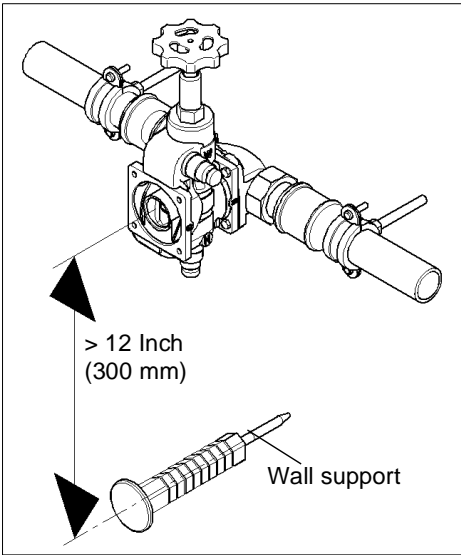

Fig. 5: Wall support with bypass valve

For further information, please refer to the installation instructions for the wall support.

4.2.6 Mounting of the Water Treatment Device

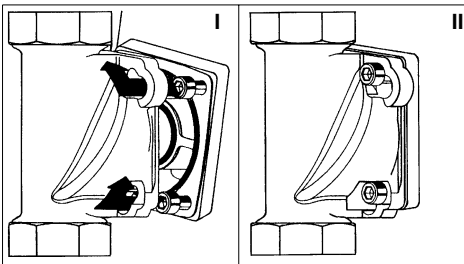

Fig. 6: Built-in rotary flange with bayonet fixture

After flushing the water pipe, remove the assembly lid of the built-in rotary flange.

Remove the white protective disc on the connecting flange of the water treatment devices by unscrewing the four M6 Allen screws.

Do not completely unscrew the screws because of the bayonet connection!

Lift up the water treatment devices and swivel it approx. 30° in an anti-clockwise direction. Position it on the built-in rotary

flange so that the screw heads pass through the bayonet fixing drill holes (see Fig. 6 I). Swivel the water treatment devices approx. 30° back in a clockwise direction and tighten the four hexagon socket screws (see Fig. 6 II).

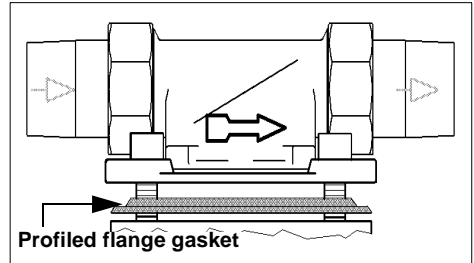

Fig. 7: Built-in rotary flange

The profile of the profiled flange gasket must point towards the built-in rotary flange. Failure to observe this can lead to leaks and water escaping. This can cause damage due to water to the house and its installations (see Fig. 7).



Select the torque (approx. 4 Nm) so that the gasket locks and the water treatment device is not damaged or strained!

4.3 Discharging the flushing water

An adequately dimensioned wastewater connection (e.g. floor drain) according to DIN 1986 must be available for the flushing water.

The dimensioning depends on the local circumstances (e.g. wastewater pipe gradient, number of pipe bends, length of the wastewater pipe, etc.). The dimensioning must at least ensure that all the wastewater can be discharged temporarily coordinated.

If it is not possible to locate a drain connection directly under the water treatment devices, the wastewater hose can be routed over the water treatment device.

The wastewater hose for the flushing water must be led to the drainage channel without any kinks.

In all options, a free discharge must be ensured in accordance with EN 1717.

The loose end of the hose has to be firmly fixed with the included adhesive tape at the pipe or a similar object.

The flushing water must be discharged into a firmly mounted drain.



Ensure that the wastewater connection functions before plugging the power supply unit into the socket.

Flushing water discharge options

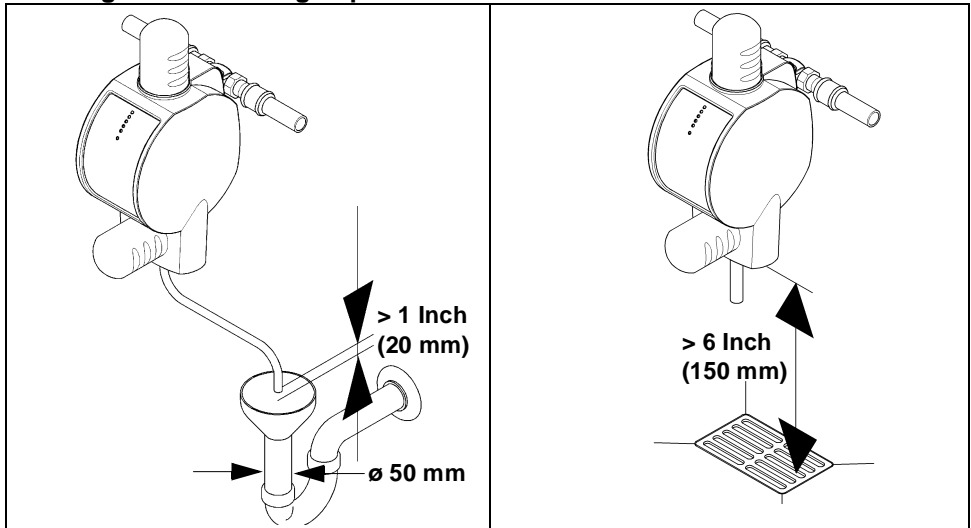

Fig. 8: Flushing water discharge options

5. Operation



ATTENTION

(see chapter "Safety information and dangers due to non-compliance")

Always observe the chapter on "Intended Use"!

5.1 Commissioning

For safety reasons, the water treatment devices must be **vented immediately** after having been connected with the water supply. Set the bypass valve supplied at the setting "Operation" (see chapter "Mounting of the Bypass Valve (accessories)").

- Turn on a water tap mounted after the water treatment devices.
- The power supply must be freely accessible.



Connect the water treatment device to the power supply. Plug the power supply into the socket.

- After the power supply has been connected, the electrical circuit performs a self-check of all the functions and parameters stored in the electronics.
- Following a successful check, all control lamps flashes four times.
- As soon as LED 1 shows a continuous green light indicating "Operation", the water treatment devices is ready for use. When water is flowing, the green LED 1 flashes (see chapter "Control lamps, manual pushbuttons").

Electrical circuit

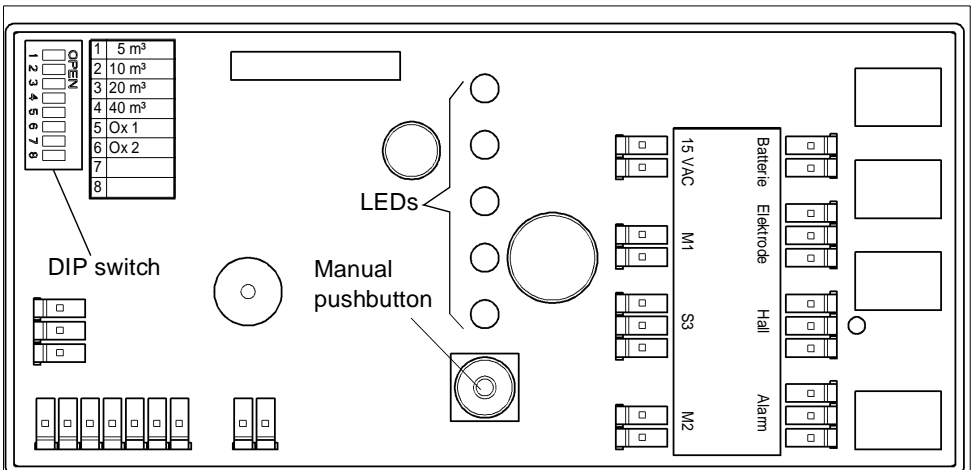

Fig. 9: Electrical circuit

5.2 Description of its function

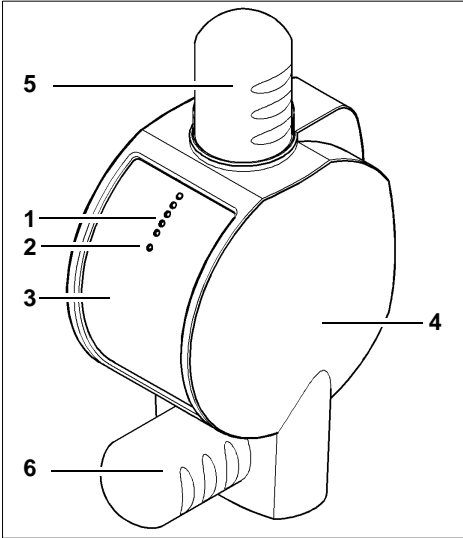

Fig. 10: BST-CA

- 1 Control lamps
- 2 Manual pushbutton
- 3 Type Plate
- 4 Panelling
- 5 Cleaning motor
- 6 Flushing motor

5.2.1 Treatment effect

The water treatment device works completely automatically. The treatment effect is adapted at the water flow. In the feed to the water treatment device there is a flow-meter.

The flow-meter consists of a propeller water meter.

Due to the water flow the screw propeller, that can be found in the propeller water meter rotates, and a Hall Sensor receives impulses from the magnet in the propeller.

The electronics then calculate the water flow from the frequency and quantity of the impulses. The electronics regulate the treatment current referring to the relation that exists between the applied voltage and the treatment current as well as from the duration of the treatment current [impulse length). The electronics optimise the treatment current, according to the quality of the water.

As soon as water flows, the water treatment is indicated by the flashing of green LED 1 (see fig. 12).

5.2.2 Lime protection function

The water treatment devices sets free the minute seed crystals to which further lime can attach itself. In the treatment section, there is a titanium anode (positive pole) and a circular stainless steel brush switched as the cathode (negative pole). As soon as water flows, there is a pulsating direct current applied to these two electrodes so that there is a flow of electricity between the electrodes. Dissolved calcium in the form of calcium carbonate crystals is then deposited on the cathode (the circular stainless steel brushes). On cleaning, these crystals of calcium carbonate are thrown off the separate bristles by rotating the circular brush. The crystals thus formed are minute micro-crystals. Larger crystals which may possibly also appear sink together with separate loose brush particles to the bottom and are flushed out via the flushing valve during cleaning.

The lime particles can be seen in the flushing water as very fine "sand". The microcrystals remain in suspension and thus form seed crystals on which further lime can be deposited. Principally in the warm water field the growth of the crystals can be realized by a gradual clouding of the water. The crystals slowly grow large enough to be able to disperse the rays of light. At that stage, they are but a few thousandths of a millimeter in size. But even these crystals are small enough to remain in suspension and to be flushed out with the water flow. The same process goes on in the cold water field, too, although the potential here for deposition of lime is considerably less in normal circumstances. Since the excess lime (calcium) is now deposited at the seed crystals, other surfaces (e.g. pipework, boiler etc.) are not affected by lime deposits so that heating elements for example no longer fur up. Although this formation of crystals does reduce the hardness of the water, the reduction is so small that they remain undetectable by means of simple measuring instruments.

In the feed of the unit, is a propeller water meter which can even detect such small flows of water as 1.5 l/min. Together with a microprocessor-controlled electronics, optimal water treatment is ensured at all times from tiny flows up to the nominal capacity, and also depending on the water quality by adapting the electrical impulses.

5.2.3 Hygiene unit

In addition to its lime-protection function, the water treatment devices also fights bacteria such as that one which causes legionnaires' disease and herewith their increase. This is achieved by means of the proven anodic oxidation method.

The hygiene unit in the water treatment devices consists of an electrode specially coated with a mixture of oxides of precious metals as an additional anode and an electronic control unit. The approved circular stainless steel brush is used here, too in the hygiene unit as a deposition cathode in addition to its function as a lime protection. The cathode brush is freed of lime depositis from time to time by means of a scraper, so that a pole reversal of the electrodes is not necessary for the cleaning off. By avoiding regular pole reversal it is taken care of the electrodes and their service life is prolonged.

As soon as the water flows, by applying a small voltage out of the water itself, without the addition of chemicals, oxidants are produced which attack the legionella bacterium.

The water treatment devices creates a disadvantageous living environment for the legionella bacteria, but must not be used, however in legionnaires' disease-contaminated water systems as the sole protection against legionnaires' disease. In these circumstances, measures for disinfection have to be adopted here as further steps, in accordance with the DVGW working sheet W551, in order to kill the legionella bacteria completely.

The use of the water treatment devices does not replace a disinfection in the usual sense, but serves as a prophylatic measure to protect as far as possible against the danger of an increase of the germs.

5.3 Control lamps, manual pushbuttons

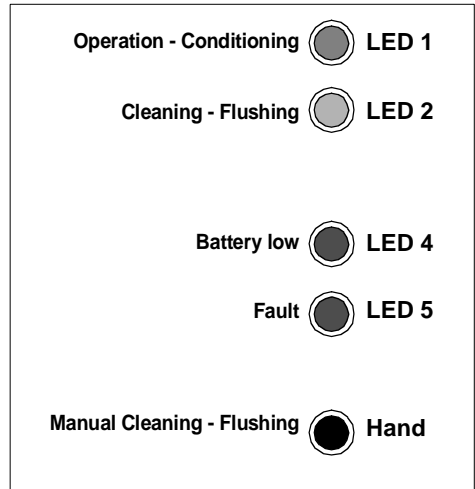

Fig. 11: Control lamps, manual pushbuttons

LED 1	Operation - Conditioning
--------------	---------------------------------

Permanent green light: the water treatment device is ready for use.

Green light flashing: water treatment is taking place.

LED 2	Cleaning - Flushing
--------------	----------------------------

Permanent green light: a flushing - flushing is being carried out.

LED 4	Battery low
--------------	--------------------

Red light flashing: the battery must be changed otherwise no further Cleaning - Flushing can be carried out.

LED 5	Fault
--------------	--------------



Red flashing light: the water treatment device is not ready for use (see chapter "Fault").

Hand	manual pushbutton
-------------	--------------------------

Triggers Cleaning - Flushing.

5.4 Cleaning - Flushing

Depending on the quality of the water and the operating methods, a thin coating of lime is formed on the brush in the treatment chamber. This lime layer must be removed and flushed out of the water treatment devices at regular intervals.

The water treatment device has a device for flushing the brush and a flush valve for rinsing out the lime particles.

Cleaning and flushing is carried out automatically by two electric motors.



Make sure that the drain connection is functional before plugging the power supply into the socket (see chapter "Discharging the flushing water").

During Cleaning - Flushing, the yellow LED 2 lights up.

The Cleaning - Flushing can be started manually by operating the manual push-button (2).

5.5 Warning message "Battery low"

To ensure that Cleaning - Flushing is carried out completely, even in case of a power failure, the water treatment appliance has a 9V block battery installed as an emergency power supply.

Before each Cleaning - Flushing a battery test will be effected. A missing, unloaded or defective battery is indicated by the flashing of the red LED 4. A triggering of the container flushing is then not possible.

5.6 Mounting of the panelling

Dismantling:



Disconnect the power supply from the socket.

- Withdraw the upper / inferior clamping fixture.
- Carefully pull apart the right and the left panel parts by the handle cavities on the back of the panelling.
- Remove the type plate and the panelling.

Assembly:

- Push the right and left parts of the panelling together till a gap of approximately 15 mm is left.
- Ensure that the cable is not trapped!
- Refit the type plate in the blanks, of the panelling, situated above and below.
- Push the panelling completely together.



Plug the power supply into the socket!

5.7 Replacing the batteries

When a change of batteries is necessary (LED 4 flashes) the following procedure is adopted:



Disconnect the power supply from the socket.

- Remove the panelling from the water treatment devices.
- The battery is located behind the electrical switch and must be disconnected from the battery clip.
- Exchange the battery and push it back into the corresponding blank behind the switch.
- Remount the panelling on the water treatment devices.



Plug the power supply into the socket!

- Return run-down batteries to a distributor or to a properly- authorised local disposal return point.



Only use 9 V alkaline type block batteries - see battery description.

5.8 Modifications / changes / spare parts



ATTENTION



(see chapter "Safety information and dangers due to non-compliance")

Only original spare parts are to be used!

Independent modifications and changes are prohibited for safety reasons! These can impair the function of the water treatment device, lead to lead and in extreme cases can cause the water treatment device to burst.

The test marks imprinted on the unit are only valid if original spare parts are used.

5.9 Stoppages



(see chapter “Safety information and dangers due to non-compliance”)

If a water treatment device has to be removed from the flange or unscrewed, the chapter on “Intended Use” must always be observed!

- Protect the flange surfaces from damage! Damaged flanged surfaces cannot close tight. As a result, escaping water can damage the building and installations.
- Ensure that no dirt can get into the water treatment device! This dirt can get into contact with and be discharged into the drinking water when the water treatment device is switched back on. The health of people who drink dirty water is at risk.
- Store the water treatment device in frost-free conditions! Frost can cause any water contained in the water treatment device voids to freeze and thus cause mechanical damage to the water treatment device so that it leaks at operating pressure or can burst. Leaking water can cause major damage to the building. In addition, people near the water treatment device can be injured by breaking off water treatment device parts.
- When restarting the water treatment device, follow the instructions for a new water treatment device.

6. Fault

The opening of the units, and the exchange from parts that are water pressure-charged have to be effected only by licensed specialists to ensure the safety of the device as well as its leak tightness.



If a fault occurs at the unit it will be indicated by the LED 5 flashing red.

Deleting the error message:



Disconnect the power supply from the socket. Plug it back in after approx. 5 seconds!

Help with faults:

Fault	Cause	Remedy
Permanent red light from LED 5 and permanent acoustic signal.	DIP switch incorrectly set.	Reset DIP switch (see chapter "Setting of the flushing interval").
LED 5 flashes red.	Momentary power failure.	Delete the failure message. The appliance reverts automatically to normal operation.
	Cable connections have become loose.	 <p>Disconnect the power supply from the socket!</p> <ul style="list-style-type: none"> – Remove the panelling (see chapter "Mounting of the panelling"). – Check the cable connections, reconnecting each plug-and-socket connection which is loose. – Remount the panelling. – Plug the power supply back into the socket.
Repeated fault message after having reconnected the power supply in the socket.		<p>Inform fitter or nearest available customer service point without any delay. Quote the appliance number. See appliance number in front of the chapter entitled "About this Operating Instructions".</p>  <p>Disconnect the power supply from the socket!</p> <p>The water treatment device has to be out of service till the arrival of the customer service. Set the bypass valve to "Bypass".</p> <p>If there is no bypass valve mounted, ensure that there is not any water escaping from the wastewater connection.</p> <p>Remove the ball-valve actuator with a sudden pull. Close the ball-valve with the included hand lever.</p>
LED 4 flashes red.	Battery is empty.	Replace by a new battery (type alkaline). Return run-down batteries to the collection points.

7. Maintenance



(see chapter "Safety information and dangers due to non-compliance")

Always observe the chapter on "Intended Use"!

7.1 Cleaning



(see chapter "Safety information and dangers due to non-compliance")

Only use clear, clean drinking water to clean the housing.

Domestic all-purpose cleaners and glass cleaners can contain up to 25% solvents or alcohol (spirits).

These substances can chemically attack the plastic parts, which can lead to brittleness or even fractures.

Such cleaners must therefore not be used.

8. Warranty and Services

To keep your legal guarantee claims, it is necessary, in accordance with DIN 1988, section 8, that, depending on the individual water consumption, a visual inspection of the device has to be effected, every 03 to 06 months, and that the unit is flushed according to the operating instructions.

In order to achieve a successful operating, and this also after the putting into service, and for many years, it is indispensable to effect a regular maintenance. Concerning the domestic water technique this is covered by DIN 1988, section 8.

A maintenance contract is the best way, to ensure a good function of the unit, and this also beyond the guarantee period.

Wherever possible, the regular servicing work and supply with consumables and wearing materials, etc. should be carried out by the specialist trade or the factory's customer service department.

9. Data Sheet

9.1 Type

JUDO BIostat-COMBIMAT
Water Treatment Device

Abbreviated name: BST-CA

9.2 Models

Model	Size	Order No.
BST-CA Type 15	¾"	8210409
BST-CA Type 25	1"	8210407
BST-CA Type 50	1½"	8210408

9.3 Technical specifications

- Maximum ambient temperature and water temperature: 86 °F (30 °C).
- **The water to be treated must possess quality of drinking water!**
- Threaded connection according to DIN 2999.

Operating pressure	Nominal pressure
22 psi (150 kPa) to 116 psi (800 kPa)	PN 10

The nominal pressure signifies the pressure step, according to that the water treatment device must fulfill the requirements according to W 510. The maximum operating pressure is lower, in order to ensure the optimal function of the water treatment device.

BST-C, BST-CA	Type 15	Type 25	Type 50
Nominal flow rate	6.6 gpm (1.5 m ³ /h)	11 gpm (2.5 m ³ /h)	2 x 11 gpm (2 x 2.5 m ³ /h)
Pressure loss at nominal flow rate	5.8 psi (40 kPa)	5.8 psi (40 kPa)	5.8 psi (40 kPa)
Pipe connection	¾"	1"	1½"
Max. power consumption	25W	25W	2x 25W
Electrical connection	230 V / 50 Hz	230 V / 50 Hz	230 V / 50 Hz
Application	One-family house	One- or two-family house	Two- to four-family house
Average daily water consumption max. 500 liters	max. 500 liters	max. 800 liters	max. 1600 liters

Installation height depends on the type of drainage (see chapter "Discharging the flushing water").

9.4 Mounting Dimensions

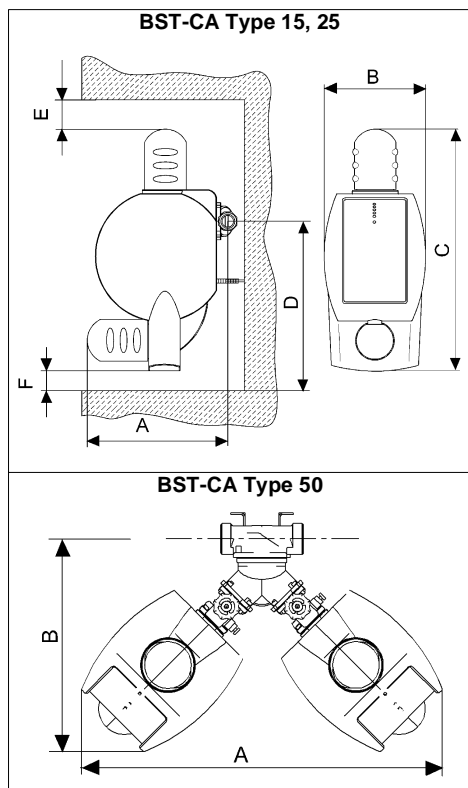

Fig. 12: Mounting Dimensions

		Type	JQX	Dimensions
A	Depth to pipe centre	Type 15, 25	without	12.6 (320)
			with	15.2 (385)
		Type 50	with	16.5 (420)
B	Width	Type 15, 25		9.0 (230)
		Type 50		27.6 (700)
C	Height			21.7 (550)
D	Minimum height to pipe			18.7 (475)
E	Minimum distance above			5.9 (150)
F	Minimum distance below			5.9 (150)

All dimensions in Inch (mm) (see Fig. 12)

9.5 Scope of supply

- Water treatment devices
- Wall support (2200500) to prevent the water treatment appliance from twisting. No support of weight!
- Built-in rotary flange JQE with threaded fitting
- Installation and Operating Instructions
- Hand lever (only BST-CA)

9.6 Accessories

- bypass valve JQX, Order No. 8735210
- Extension QUICKSET JQR for series connection of two JUDO units (e.g. filter and water treatment device) to a built-in rotary flange, Order No. 8250041

9.6.1 Protective measures against corrosion

Our recommendation for corrosion problems in cold water:

A metering pump JUDO JULIA has to be mounted on the water pipe after the water treatment device, in order to enrich proportionally the water with a mineral solution JUL.

Mineral solutions JUL contain active components which create the conditions in which a homogeneous protective coating can be formed in the system of pipework located thereafter. These active components correspond to the prescribed type, quality and quantity, according to in article 11 Drinking Water Regulations 2001 on treatment substances and disinfection methods.

10. Spare Parts BIostat-COMBIMAT

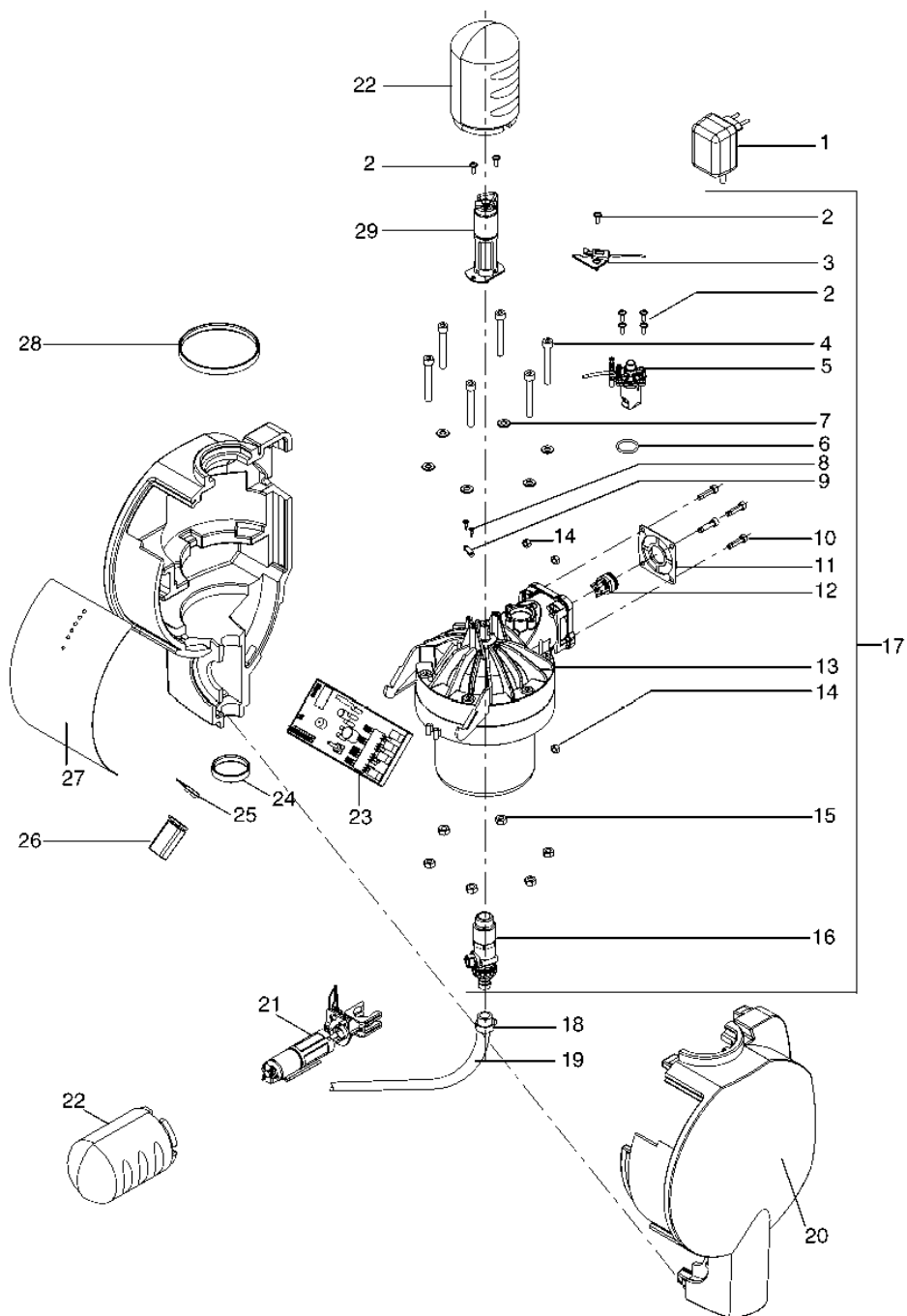

List of Spare Parts BIostat-COMBI, BIostat-COMBIMAT

Item	Description (Recommended average replacement interval for wearing part [*)	piece	Order No.	
1	Power supply complete	1	2201006	
2	EJOT- screw	7	1650201	
3	Spare parts kit for sliding contact	1	2210447	
4	Cheese head screw M8x65	6	1650365	
5	Water meter - insert	****	1	2210292
6	O-ring 21.89x2.62	****	1	1200125
7	Disc A8.4	6	1607125	
8	Screw 2.9x13	2	1609172	
9	Strain relieving bracket	1	1609114	
10	Cheese head screw M6x25	4	2010199	
11	Profiled flange seal	**	1	1200218
12	Backflow preventer 1"	1	1610287	
13	Spare parts kit for basic unit	1	2210448	
14	Hexagonal nut M6	4	1633145	
15	Hexagonal nut M8	6	1607117	
16	Spare parts kit for rinsing hose connection	1	2210449	
17	Basic unit complete	1	2210450	
18	Hose clamp	1	1633344	
19	Hose to drain	1	2633342	
20	Covers	1	1140103	
21	Spare parts set for flushing motor	1	2210445	
22	Engine cowling	2	1140101	
23	Electric circuit Type 15	1	2210325	
23	Electric circuit Type 25	1	2210326	
24	Guard Ring small	1	1120624	

Item	Description (Recommended average replacement interval for wearing part [*])	piece	Order No.
25	Battery cable	1	2210286
26	E-block-battery 9V	1	1500261
27	Front foil	1	1701393
28	Guard Ring large	1	1120625
29	Brush drive complete	1	2210348

Replacement interval: ** = 2 years, *** = 3 years, **** = 4 years

11. Customer Service



JUDO Water Treatment Inc.

2060 Steeles Ave. West, Unit 4
Concord, Ontario L4K 2V1

Phone: (905) 761-1555

Fax: (905) 761-3335

E-Mail: service@judo-online.com

www.judo-online.com

Installed by:

All illustrations, dimensions and information for the different models are those valid on the date of printing. All rights are reserved for modifications as a result of technical progress or further developments. Claims with regard to models or products are excluded.

1701641 • 2009/08