

Installation and operating instructions

JUDO BIOSTAT 2050 -2200

Water treatment installation

Valid for: Canada

Language: English

Attention:

Carefully read through the installation and operating instructions and safety information before installing and putting the unit into service.

These instructions must always be issued to the owner/user.

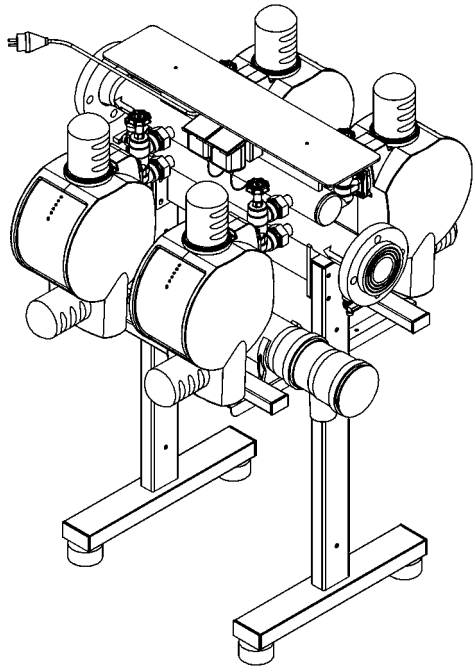

Fig.: BST 2100



DVGW tested stand-alone devices
BIOSTAT 25 TGA



Corporate Head Office

JUDO Wasseraufbereitung GmbH
P.O. Box 380
D-71351 Winnenden
Germany

e-mail: info@judo.eu
www.judo.eu

Manufacturing

JUDO Wasseraufbereitung GmbH
Hohreuschstraße 39-41
D-71364 Winnenden
Germany

Dear Customer,

thank you for the confidence you have shown in us by purchasing this installation. With this water treatment installation you have purchased an installation that fully corresponds to the most updated standards of technology.

This water treatment installation is suitable for use in cold drinking water up to a maximum ambient temperature of 86° F (30 °C).

Each installation is thoroughly checked before delivery. If any difficulties occur, please contact the responsible customer service (see back page).

Trademarks:

Trademarks used in this document are protected and registered trademarks of the respective holder.

© JUDO Wasseraufbereitung GmbH
D-71364 Winnenden

All rights reserved.
Reprints – even of extracts – are only permitted with special written approval.

Federal Communication Commission Interference Statement

This equipment has been tested and found to comply with the limits for a Class B digital device, pursuant to Part 15 of the FCC Rules. These limits are designed to provide reasonable protection against harmful interference in a residential installation. This equipment generates, uses and can radiate radio frequency energy and, if not installed and used in accordance with the instructions, may cause harmful interference to radio communications. However, there is no guarantee that interference will not occur in a particular installation. If this equipment does cause harmful interference to radio or television reception, which can be determined by turning the equipment off and on, the user is encouraged to try to correct the interference by one or more of the following measures:

- Reorient or relocate the receiving antenna.
- Increase the separation between the equipment and receiver.
- Connect the equipment into an outlet on a circuit different from that to which the receiver is connected.
- Consult the dealer or an experienced radio / TV technician for help.

FCC Caution: To assure continued compliance, any changes or modifications not expressly approved by the party responsible for compliance could void the user's authority to operate the equipment.

This device complies with Part 15 of the FCC Rules. Operation is subject to the following two conditions: (1) this device may not cause harmful interference, and (2) this device must accept any interference received, including interference that may cause undesired operation.

Table of contents

1. About this operating instructions.... 4
 1.1 Symbols used..... 5
 1.2 Safety information and dangers due to non-compliance 5
 1.3 Units used..... 5
2. Intended use 6
 2.1 Water pressure 6
 2.2 Notes on special dangers 7
3. Product information 8
 3.1 Intended purpose..... 8
 3.2 Test marks 8
 3.3 Materials used 8
4. Installation 9
 4.1 General..... 9
 4.2 Requirements for the place of installation..... 9
 4.3 Power supply..... 9
 4.4 Mounting the water treatment installation BST 2050..... 9
 4.5 Mounting the water treatment installations BST 2100, 2150, and 2200..... 11
5. Operation 14
6. Warranty and services 14
7. Data sheet 15
 7.1 Type..... 15
 7.2 Models 15
 7.3 Technical characteristics 15
 7.4 Mounting dimensions BST 2050 16
 7.5 Mounting dimensions BST 2100, 2150, 2200..... 17
8. Spare parts BST 2050, 2100, 2150, 2200 18
9. Customer service 20

1. About this operating instructions

This users' manual should always be kept near the actual device in operation.

This instruction manual is intended to make it easier to familiarize yourself with the water treatment installation and its possible intended uses.

The instruction manual contains important information required for the safe, correct and economical use of the installation concerned.

It contains fundamental information, which must be observed during installation, operation and maintenance. Observance of this information helps to avoid dangers, reduce repair costs and increase the reliability and working life of the water treatment installation.

The instruction manual must be read and used by each person entrusted with carrying out work on the water treatment installation, for example:

- **installation**
- **operation**
- **maintenance**
(servicing, inspection, repair)

Installation and maintenance may only be carried out by personnel authorized by the manufacturer, who are capable of fulfilling the instructions given in the installation and operating instructions and the country-specific prescriptions.

Apart from the instruction manual and the laws governing health & safety applicable in the country and place of use, the recognised technical regulations for safe and proper work must also be observed.

Therefore, this instruction manual must always be read by the fitter and responsible skilled personnel/owner or operator before installation, commissioning and maintenance.

Unit no.:

Not only the general safety notes given in the chapter “Intended use” are to be observed, but also the special safety notes inserted under the other main items.

1.1 Symbols used

The safety notes contained in this instruction manual are labelled with the following symbols:

 **ATTENTION**  Notes on existing dangers

 Warning, electrical voltage

 Torques specified by the manufacturer

 Tips for use and other information

Notes directly attached to the water treatment device, e.g.:

- direction of flow (see fig. 1)
- type plate
- cleaning information

must always be observed and kept in a fully legible condition.

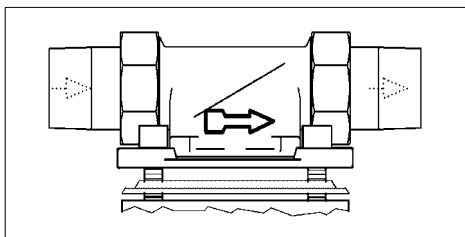

Fig. 1: Built-in rotary flange

1.2 Safety information and dangers due to non-compliance

Failure to observe the general danger symbols may result, for example, in the following risks:

- failure of important functions of the water treatment installation.
- danger to persons due to electrical and mechanical effects.
- danger to persons and the environment due to leaks.

Refrain from any unsafe working methods.

Failure to comply with this instruction manual and the safety information can not only result in dangers for people but can also harm the environment and the installation.

1.3 Units used

In derogation of the International System of Units (SI = System International), the following units are used:

Unit	Conversion
°F	°F = 9/5 °C + 32
psi	1 bar = 15 psi
gpm	1 m ³ /h = 4.4 gpm
gal	1 m ³ = 264 gal
1½"	DN 40
2½"	DN 65

2. Intended use

Installation and use of the water treatment installations are each subject to the applicable national regulations.

Apart from the instruction manual and the legally binding accident prevention provisions applicable in the country and place of use, the recognized technical regulations for safe and proper work must also be observed.

The water to be treated must comply with the European Drinking Water Directive!

Always contact the manufacturer/supplier before using water with a different quality or with additives!

This water treatment installations is suitable for use in cold drinking water up to maximum ambient temperature of 86 °F (30 °C).

It is produced according to the newest standards of technology and the generally accepted safety regulations in Germany.

The water treatment installations may only be used as described in the instruction manual. Any other or further use is deemed not to be intended use.

Additional dangers exist in case of non-intended use and failure to observe the danger symbols and safety information. The manufacturer/supplier are not liable for any losses or damage resulting from this. The risk is solely borne by the user.

Intended use also includes observing the instruction manual.

The manufacturer/supplier must always be consulted before using the water treatment installations outside the use limitations given in the instruction manual.

The water treatment installations are only to be used in a technically perfect condition, for their intended use, safely and aware of the dangers and with full observance of the instruction manual!

Have any malfunctions corrected immediately!

In order to be able to discharge safely the wastewater in operation and in case of any defect in the system, precise compliance with the details stated in the chapter "Requirements for the place of installation" is necessary!

2.1 Water pressure

The water pressure must be between 22 psi (1.5 bar) and 116 psi (8 bar).

If the water treatment installation is not regularly regenerated, this can result in a pressure loss and impairment of the softening function.



(see chapter "Safety information and dangers due to non-compliance")

If the **water pressure is more than 116 psi (8 bar)** a pressure reducer must be installed **before** the water treatment installation (see fig. 2). An operating pressure of more than 116 psi (8 bar) can lead to malfunction and failure.

The optimal operating pressure for the water treatment installation lies between 44 psi (3 bar) and 73 psi (5 bar). It works most economically under these pressure conditions. In modern sanitary installations (in particular where single lever mixers are used), despite normal system pressure conditions, peak pressures of up to over 435 psi (30 bar) frequently occur. This can cause damage to important functional interior parts of the water treatment installation.

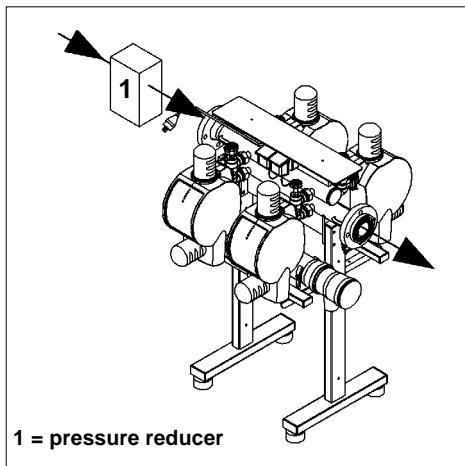

1 = pressure reducer

Fig. 2: Pressure reducer upstream of the water treatment installation (example: BST 2100)

i For a **water pressure of 73 psi (5 bar) to 116 psi (8 bar)** we recommend the installation of a pressure reducer.

2.2 Notes on special dangers

2.2.1 Electrical equipment / installations



There must not be any electrical cables and devices underneath or in the immediate vicinity of the water treatment installation!

Electrical devices / equipment, which are not splash proof and which are located near the water treatment installation can be damaged by water which escapes from the water treatment installation during cleaning/flushing or improper use. If the electrical devices / installations are connected to the power supply, a short circuit can also occur. In this case there is a risk of people suffering an electric shock. Electrical devices / equipment located near the water treatment installation must therefore be splash proof and comply with the legal regulations for wet rooms (IP44).

3. Product information

3.1 Intended purpose

This water treatment installation is suitable for use in cold drinking water up to a maximum water temperature of 86 °F (30 °C).



ATTENTION

(see chapter “Safety information and dangers due to non-compliance”)

Please refer to the chapter “Intended use” for use restrictions.

This water treatment installation reduces the tendency of the water to precipitate out excess calcium and thus protects the water-pipes and water heaters from lime deposits.

Appliances and taps are protected.



Lime deposits restrain the water flow and can therefore lead to an increased energy consumption.

3.2 Test marks



Fig. 3: DVGW mark

The installations conform to the technical regulations for drinking water installations in accordance with the German standard DIN 1988.

The BIOSTAT water treatment devices (type TGA) comply with the requirements of the work sheet W 510 (lime protection devices for use in drinking water installations) issued by the DVGW (Deutsche Vereinigung des Gas- und Wasserfaches e.V.), the German technical-scientific association for the gas and water industries, and are entitled to bear the DVGW mark (see fig. 3).

3.3 Materials used

The materials used are resistant to the physical, chemical and corrosive loads to be expected in the drinking water. All materials are hygienically and physiologically safe. Plastics fulfill the official guideline of the German Federal Environmental Agency as well as the work sheet W 270 issued by the DVGW. Metallic materials fulfil the requirements of the German standard DIN 50930-6 (influence on drinking water condition).

4. Installation

4.1 General



ATTENTION

(see chapter "Safety information and dangers due to non-compliance")

The installation may only be installed by skilled personnel.

The chapter "Intended use" has always to be observed !

Always observe the given spacings to ensure convenient operation and servicing (see the chapter concerning the mounting dimensions).

A space of at least 6 inch (150 mm) above the water treatment installation is required in order to be able to carry out properly all the maintenance and servicing work.

When installing the water treatment installation in the feed-pipe to the water heater, ensure that the safety valve of the water heater is located **after** the water treatment installation in the direction of flow.

4.2 Requirements for the place of installation

The room where the unit is installed must be dry and frost free!

Unauthorised persons must not have access to the water treatment installation!



ATTENTION

(see chapter "Sicherheitshinweise und Gefahren bei Nichtbeachtung")

- The ambient temperature must not exceed 86 °F (30 °C)!
- We recommend that the water treatment installation is installed after a backwash protective filter, to prevent particles of dirt and sand being swept in.



A power connection (120 V, 60 Hz) that is permanently energized must be available.

- Length of the power lead is approximately 118 inch (3 m).

4.3 Power supply



A splash proof socket is required for the power supply, in accordance with the legal regulations for wet rooms.



ATTENTION



(see chapter "Safety information and dangers due to non-compliance")

A permanent power supply that is not connected to a light switch must be available. If the water treatment installation is not permanently supplied with power, there is no warning in case of faults, and no water is treated.

Do not plug in other current consumers than the BIOSTAT water treatment devices.

4.4 Mounting the water treatment installation BST 2050

The two BIOSTAT water treatment devices (type TGA) are connected to the piping via the quickset for parallel installation (JQP). The space required for the installation can be found in chapter "Mounting dimensions BST 2050".

The pipes must be able to support the water treatment installation safely.

If not, mechanical damage or fractures/bursts can occur in the pipes. This can result in major water damage. People close to the water treatment installation are exposed to a health risk due to the large quantities of water released. Therefore, if necessary, the pipes must be additionally fixed or supported.

4.4.1 Mounting the built-in rotary flange

The built-in rotary flange is used as a connecting element between the pipe and the water treatment installation.

It is suitable for both, horizontally and vertically mounted pipes.

The built-in rotary flange must be installed in the direction of flow. This is marked by a cast in arrow (see fig. 4).

If these instructions aren't respected, the water treatment device doesn't work.



(see chapter "Safety information and dangers due to non-compliance")

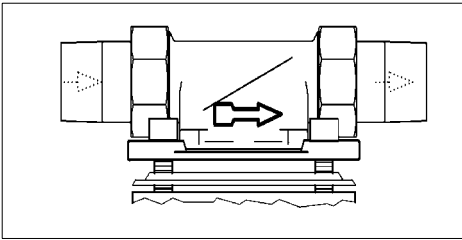

Fig. 4: Built-in rotary flange

The flange surface of the built-in rotary flange must be in a vertical position! The built-in rotary flange must be fitted thus that mechanical stresses cannot occur! Otherwise mechanical damages can arise at the built-in rotary flange. This can lead to major water damages.

In this case, people close to the water treatment installation are exposed to a health risk due to the large quantities of water.

Therefore, when mounting, ensure that no large forces act on the pipe, built-in rotary flange and water treatment installation.

4.4.2 Mounting the quickset for parallel installation (JQP)

- After flushing the water pipe, remove the assembly lid of the built-in rotary flange.
- Verify that the profiled flange seal is placed correctly (profile must point towards the built-in rotary flange).
- Screw the quickset for parallel installation and the built-in rotary flange together.

4.4.3 Mounting the support

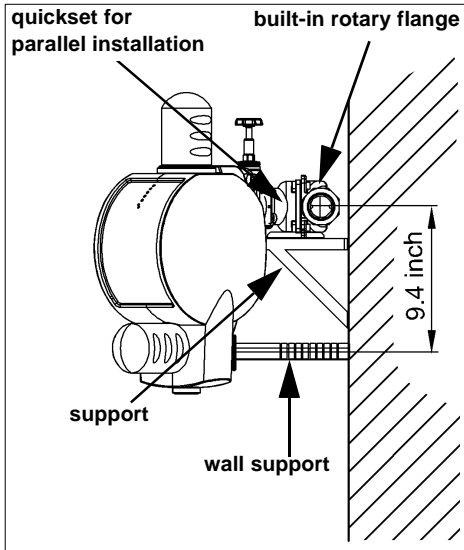

Fig. 5: Wall support

The support is mounted directly below the quickset for parallel installation (JQP). It is screwed to the wall with 4 hexagonal screws (8x60). The support needs to rest against the built-in rotary flange flushly.

Information on the wall support can be found in the mounting instructions for the wall support.

4.5 Mounting the water treatment installations BST 2100, 2150, and 2200

The space required for the entire water treatment installation can be found in the chapter "Mounting dimensions BST 2100, 2150, 2200".

We recommend:

- a shut-off valve in front of and behind the distributor.

The distributor has a loose flange with a flange bushing for a connection flange according to ISO 7005 and DIN 2501 (hole circle PN10) at the water intake and outtake respectively (see fig. 6).

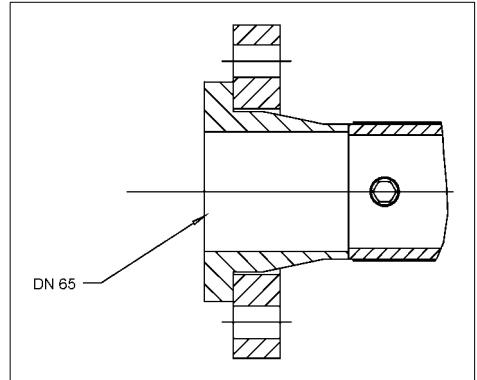

Fig. 6: Connection of a single unit

4.5.1 Setting up the distributor

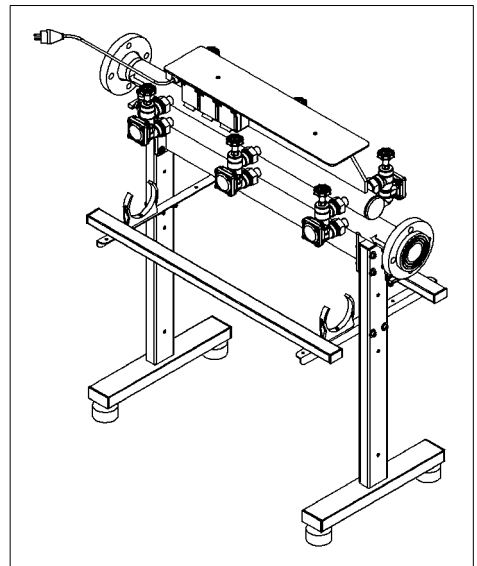

Fig. 7: Dsitrubutor and rack

4.5.2 Connecting the pre-assembled distributor to the drinking water pipe

- Check the scope of supply for completeness.
- Position the pre-assembled distributor at the designated installation location.
- Turn off the drinking water.
- Connect the pre-assembled distributor to the drinking water pipe.



Mind the water flow direction!



Drinking water intake and outtake have different mounting heights.

- Between the open endings of the drinking water pipe must be a distance that corresponds to the distributor to be sheeted plus two flat seals.
- Screw the loose flanges of the distributor and the loose flanges of the drinking water pipe strainlessly together.
- Open the shut-off valve, flush the drinking water piping and check for leak tightness.

4.5.3 Flushing water connection

- can be done via a drain pipe (maximum height 21.7 inch (550 mm))
- can be done via a lifting device
- can be done via a floor drain

All these possibilities for the flushing water connection have in common that a free run-out according to the standard DIN 1717 must be considered.

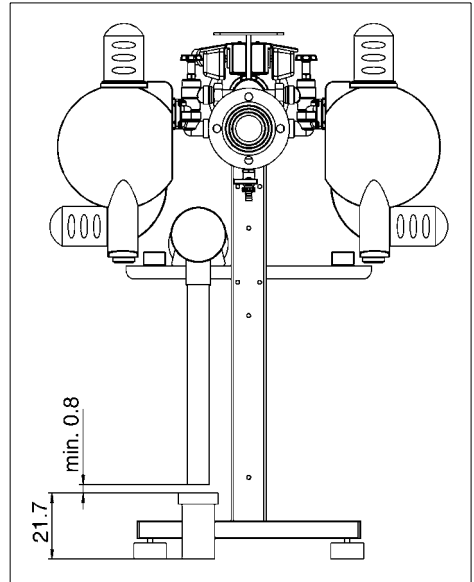

Fig. 8: Flushing water connection
(All dimensions in inch)

4.5.4 Mounting the BIOSTAT stand-alone devices (type TGA)

- Turn off the water.
- Remove the black sealing caps of the shut-off valves.
- Remove the white protective cap from the BIOSTAT water treatment device (type TGA).
- Unscrew the four Allen screws (M6x25) at the water treatment device.
- Screw the water treatment device on the shut-off valve using the four Allen screws (M6x25).

Further information can be found in the installation and operating instructions for the BIOSTAT TGA.



The profile of the profiled flange gasket must point towards the shut-off valve.



Select the torque (approx. 4 Nm) so that the gasket locks and the water treatment installation is not damaged or strained!

Flushing water connection

Shorten the flushing water hoses on the devices and mount them on the hose nipples of the wastewater connection pipe without any kinks.

Electrical connection

The power supplies of the BIOSTAT water treatment devices (type TGA) have to be plugged into the power sockets that are mounted on the rack.

The power plug of the water treatment installation must be inserted into a splash proof socket that complies with the legal regulations for wet rooms. The power socket must be permanently energized (see chapter “Power supply” and chapter “Electrical equipment / installations”).

5. Operation

Detailed information on the operation can be found in the installation and operating instructions of the water treatment device BIOSTAT 25 TGA.

6. Warranty and services

To keep your legal guarantee claims, it is necessary, in accordance with DIN 1988, section 8, that, depending on the individual water consumption, a visual inspection of the installation has to be effected, every 3 to 6 months, and that the installation is flushed according to the operating instructions.

In order to achieve a successful operating, and this also after the putting into service, and for many years, it is indispensable to effect a regular maintenance. Concerning the domestic water technique this is covered by DIN 1988, section 8.

A maintenance contract is the best way, to ensure a good function of the installation, and this also beyond the guarantee period.

Wherever possible, the regular servicing work and supply with consumables and wearing materials, etc. should be carried out by the specialist trade or the factory's customer service department.

7. Data sheet

7.1 Type

JUDO BIOSTAT 2050 - 2200
water treatment installations

Abbreviated name: BST

7.2 Models

Model	Order no.
BST 2050	8210356
BST 2100	8210357
BST 2150	8210358
BST 2200	8210359

7.3 Technical characteristics

- Maximum ambient temperature and water temperature: 86 °F (30 °C).
- **The water to be treated must possess quality of drinking water!**
- Threaded connection according to DIN EN 10226-1.

Operation pressure	Nominal pressure
2 – 7 bar	PN 10

The nominal pressure signifies the pressure step, according to that the water treatment installation must fulfil the requirements according to W 510. The maximum operating pressure is lower, in order to ensure the optimal function of the water treatment installation.

	BST 2050	BST 2100	BST 2150	BST 2200
Shipping weight	50 kg	120 kg	180 kg	280 kg
Nominal flow rate	22 gpm (5 m ³ /h)	44 gpm (10 m ³ /h)	66 gpm (15 m ³ /h)	88 gpm (20 m ³ /h)
Minimum flow pressure at nominal flow rate	29 psi (2 bar)	29 psi (2 bar)	29 psi (2 bar)	29 psi (2 bar)
Pressure loss at nominal flow rate	7.3 psi (0,5 bar)	7.3 psi (0,5 bar)	7.3 psi (0,5 bar)	7.3 psi (0,5 bar)
Pipe connection	1½"	DN 65	DN 65	DN 65
Electrical connection	120 V / 60 Hz	120 V / 60 Hz	120 V / 60 Hz	120 V / 60 Hz
Max. power consumption	50 W	100 W	150 W	200 W

7.4 Mounting dimensions BST 2050

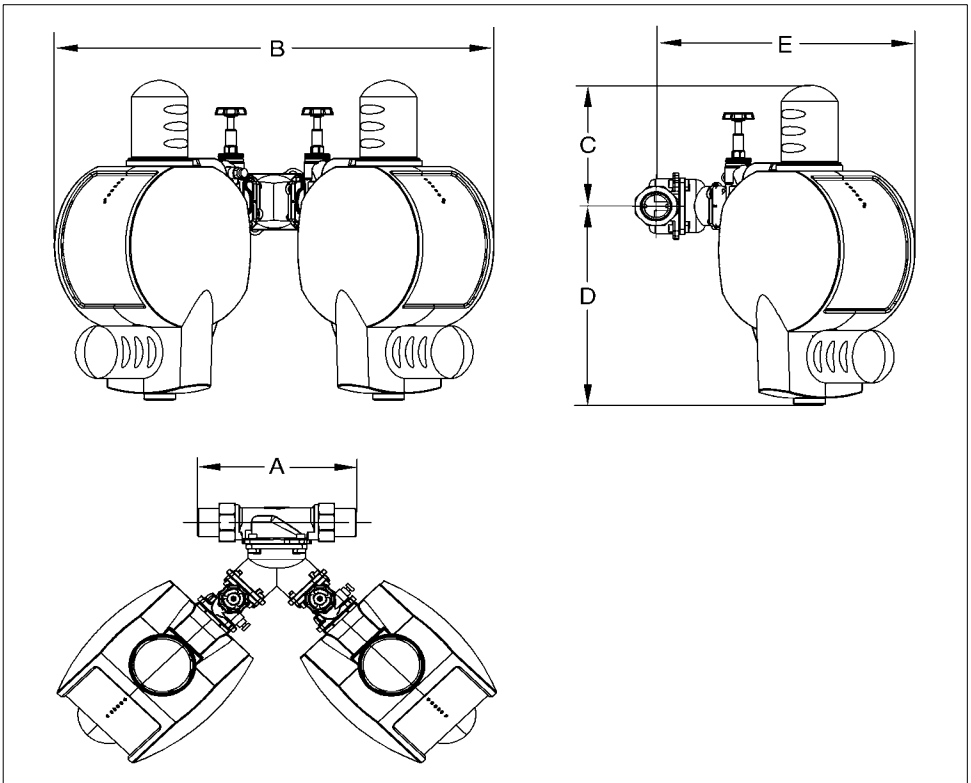

Fig. 9: Mounting dimensions BST 2050

A	= mounting length (rotary flange)	10 (255)
B	= installation width	28 (700)
C	= height above pipe center	8 (210)
D	= height below pipe center	14 (350)
E	= mounting depth to pipe center	16 (415)

All dimensions in inch (mm) (see fig. 9)

7.4.1 Scope of supply BST 2050

- Two water treatment devices
BST TGA
- Quickset for parallel installation (JQP)
- Accessories bag
- Installation and operating instructions
- Wall support
- Hand lever

7.5 Mounting dimensions BST 2100, 2150, 2200

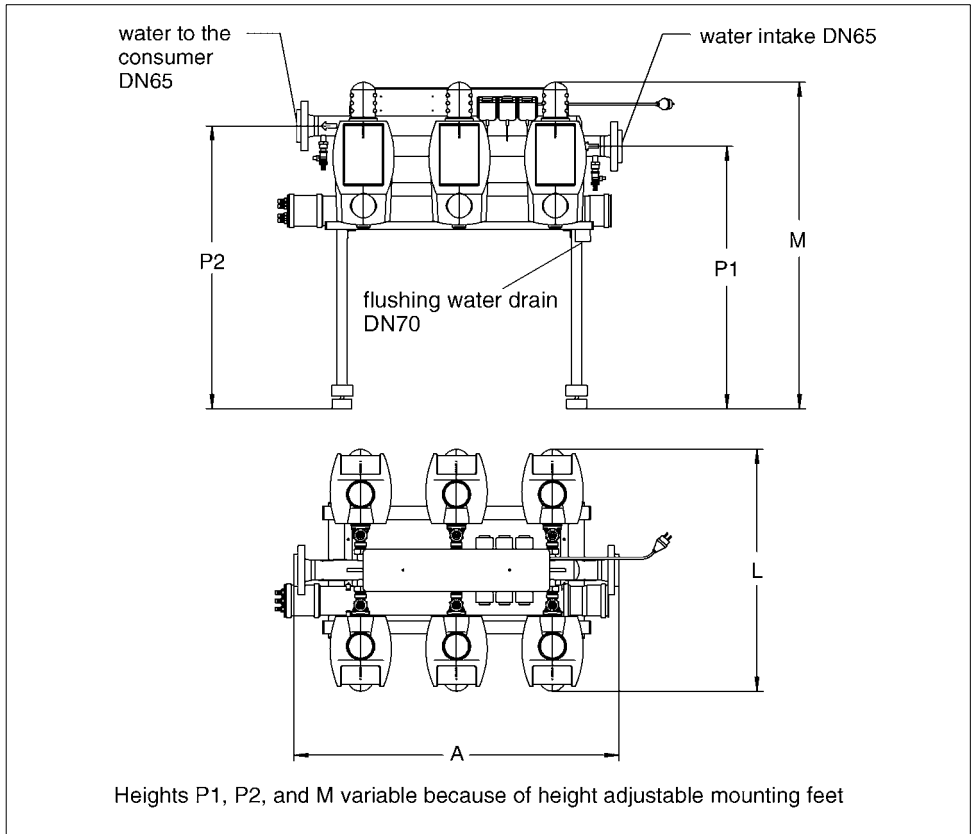

Fig. 10: Mounting dimensions (example: BST 2200)

	BST 2100	BST 2150	BST 2200
A = mounting length	appr. 34 (860)	appr. 48 (1220)	appr. 62.2 (1580)
L = total depth	35.8 (910)	35.8 (910)	35.8 (910)
P1 = height to pipe center	appr. 38.6 (980)	appr. 38.6 (980)	appr. 38.6 (980)
P2 = height to pipe center	appr. 42 (1060)	appr. 42 (1060)	appr. 42 (1060)
M = total height	48.4 (1230)	48.4 (1230)	48.4 (1230)

All dimensions in inch (mm) (see fig. 10)

7.5.1 Scope of supply BST 2100, 2150, 2200

- water treatment devices BST TGA
- installation and operating instructions
- distributor (pre-mounted)

8. Spare parts BST 2050, 2100, 2150, 2200

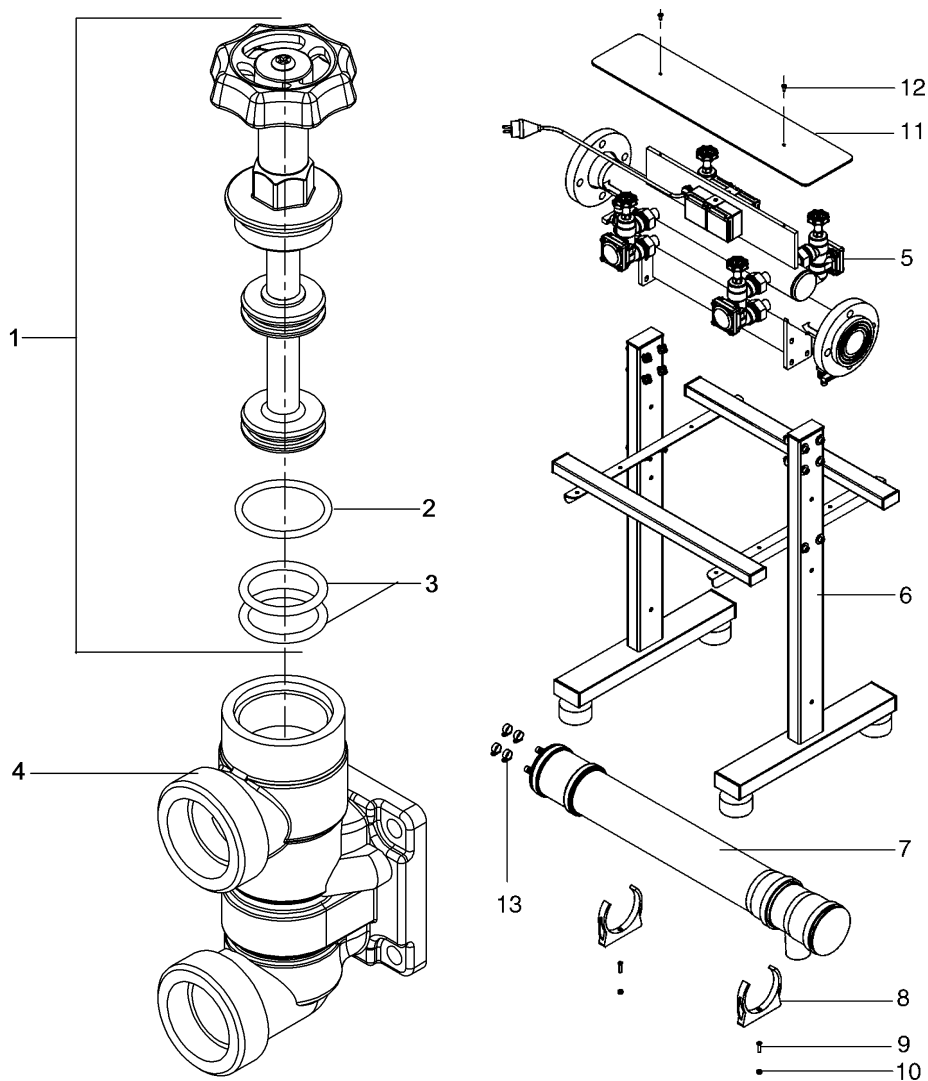

Item	Description (Recommended average replacement interval for wearing part [**])	Piece	Order no.	AU ¹⁾ /piece
1	Valve spindle - upper part	1	2250164	117
2	O-ring 29x3	** 1	1200239	1
3	O-ring 17x3,5	2	1200026	2
4	Casing	1	2250169	330
5	Water distributor JUDO BIOSTAT 2100	1	2201329	on request
5	Water distributor JUDO BIOSTAT 2150	1	2201330	on request
5	Water distributor JUDO BIOSTAT 2200	1	2201331	on request
6	Rack compl. JUDO BIOSTAT 2100	1		on request
6	Rack compl. JUDO BIOSTAT 2150	1		on request
6	Rack compl. JUDO BIOSTAT 2200	1		on request
7	Wastewater collection pipe JUDO BIOSTAT 2100	2	2210413	
7	Wastewater collection pipe JUDO BIOSTAT 2150	2	2210414	
7	Wastewater collection pipe JUDO BIOSTAT 2200	2	2210415	
8	Goema pipe clamp	4	1130154	15
9	Flat head screw M6x25	4	1650074	1
10	Hexagonal nut M6	4	1633145	1
11	Cover JUDO BIOSTAT 2100 (printed)	1	2201102	195
11	Cover JUDO BIOSTAT 2150 (printed)	1	2201103	195
11	Cover JUDO BIOSTAT 2200 (printed)	1	2201104	195
12	EJOT screw	2	1650201	2
13	Hose clamp	1	1650369	
	Wall support complete (BIOSTAT 2050) (see fig. 5)	2	2200500	11

1) AU = Accounting unit

Replacement interval: ** = 2 years

9. Customer service



JUDO Water Treatment Inc.

2060 Steeles Ave. West, Unit #4

Concord, Ontario L4K 2V1

phone: (905) 761-1555

fax: (905) 761-3335

e-mail: service@judo-online.com

www.judo-online.com

Installed by:

<p>JUDO JULIA Metering pump for JUL mineral solution against corrosion (brown water) and lime deposits.</p>	<p>JUDO HEIFI-KOM Combination of the heating backwashing filter and automatic heating feed station for fulfilment of DIN EN 1717.</p>	
<p>JUDO PROMI domestic water station Backwash protective filter with JUDO PROFI-PLUS technology, pressure reduce and backflow preventer.</p>	<p>JUDO ZEWA-WATERSTOP Central water safety fitting. Stops water flow in the event of water pipe bursts and detects leaks.</p>	<p>JUDO PROFI-PLUS Backwashing protective filter in the germ protection class with silver plated strainer and point rotation system for optimal cleaning of the strainer.</p>

All illustrations, dimensions and information for the different models are those valid on the date of printing. All rights are reserved for modifications as a result of technical progress or further developments. Claims with regard to models or products are excluded.

1702208 • 2010/04