

Operating instructions

BioQuell-K

Water softener

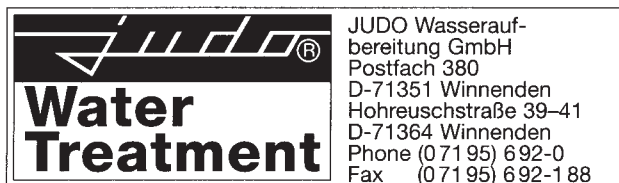
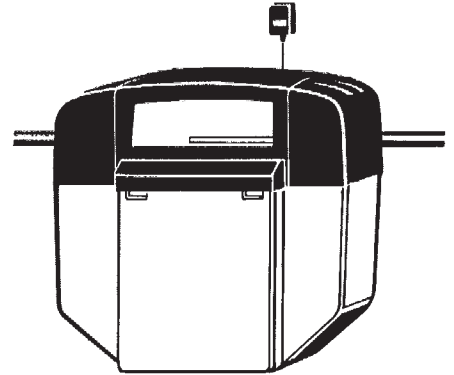

Dear Customer,

When purchasing the BioQuell-K, you decided to buy a unit representing the latest technical, economical and hygienic state of the art in the water treatment technology.

Range of application as per DIN 1988 part 2 sect. 8.3.2.

There are no limits as to the application range as per DIN 1988 part 2 section 8.3.2 (edition December 1988). The softener capacity of the BioQuell-K is designed as to partially soften the entire water for a detached family house or a house for several families as well as the corresponding partial quantities of water required for warm water, for the swimming pool, the washing machine or the dishwasher.

Purpose of application (also see DIN 1988 part 7 section 4.2.2) The BioQuell-K is intended for protecting the water pipes as well as the water heater from calcareous deposits which could slow down the water flow and lead to a high energy consumption. Devices and fittings are saved, thus avoiding costly repairs. Consumption of detergents and cleansing agents is considerably lower with semisoftened water.

Mode of operation

The BioQuell-K is a dual system consisting of two similar filter cells, one of which is constantly operating while the other is regenerated in the meantime. The consumer thus always disposes of softened water. A water meter installed in the soft water pipe allows to switch from one filter cell to the other when one filter cell is exhausted. This means that no exchange capacity is lost and the BioQuell-K thus works extremely economical. Furthermore, it is regenerated with an economical salting so that it only requires slightly more than quarter of the regeneration salt of conventional softeners.

The two filter cells of the BioQuell-K are filled with ion exchange resin. These are small synthetic resin balls where the calcium ions which „harden“ the water are exchanged through sodium ions. This softens the water.

The ion exchange resin, however, only absorbs a limited quantity of hardness components. Depending on the water hardness, it is exhausted sooner or later. The exhaustion time is recorded by the adjustable water meter calibrated in Degrees of German Hardness (°dH) and when switching over to the other filter cell, regeneration is automatically started. This means that diluted brine (sodium chloride) removes the hardness components from the resin.

Regeneration is automatically carried out by means of 13 control and 4 main valves. The regeneration program is firmly adjusted in a program cylinder and has not to be reprogrammed after a power failure as this is partially the case with other installations.

Technical Data:	Europe	N-America
Nominal flow:	2 m ³ /h	528 US gallons
Temporary max. flow	3.5 m ³ /h	924 US gallons
Pipe connection (External thread)	1 inch	1 inch
	1 1/4 inch	1 1/4 inch
Nominal capacity	2 x 1.6 mol	2 x 1.6 mol
	PN 10	145 psi
Operating pressure max.*	7 bar	100 psi
Flow pressure with nominal flow min.	2 bar	30 psi
Operating temperature max.	30 °C	86 °F
Contents of salt supply tank	40 kg	88 pds
Salt consumption per regeneration	0,24 kg	0,53 pds
Sewage per regeneration with 4 bar	20 liters	5,28 US gallons
Electrical connection	230 V/50 Hz/10 VA	110 V/60 Hz/10 VA
	85 kg	187 pds
	32 kg	71 pds

* With modern sanitary installations (especially when single-lever mixers are used), pressure peaks of more than 30 bar often occur despite normal nominal pressures. This may possibly lead to the damage of operational inside parts of the control.

The optimum service pressure for the BioQuell-K is 3 - 5 bar at which pressure it runs most efficient.

We therefore recommend to install a pressure reducer with higher pressures. The following device (combinations) provide optimum solutions: JUDO safety block in connection with the JUDO PROFI- or the JUNIOR-backwashing protection filter, Check-Point KERFI or Check-Point SPÜLI.

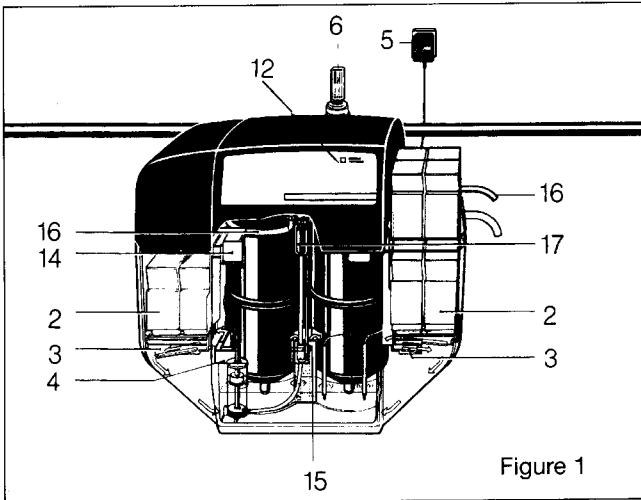

Figure 1

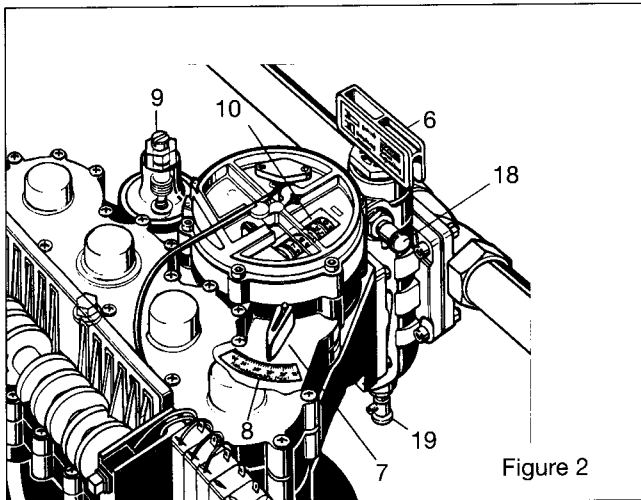

Figure 2

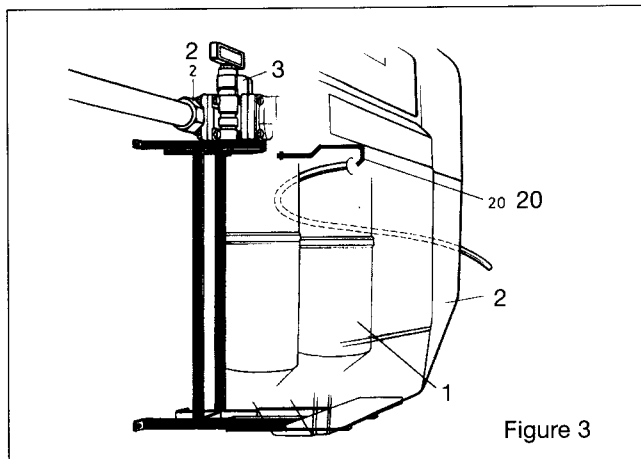

Figure 3

1. BioQuell-K
2. Salt supply chambers
3. Intermediate bottoms
4. Brine tank
5. Power supply unit
6. JUDO-Quickset-X-single lever by-pass valve
7. Adjusting lever for natural water hardness
8. Scale natural water hardness
9. Water down
10. Water meter
(Display of number of dual regenerations)
12. Sterilisation display and push button for hand regeneration
14. Display of lack of salt
15. Filling hose for brine tank
16. Sewage hose to channel (Observe maintenance 3!)
17. Suction control with suction hose from brine tank
18. Test valve (W) for testing the mixed water hardness
19. Test valve (H) for testing the natural water hardness
20. Locking screw for supply tank
21. Holding clamp for supply tank

Commissioning

1. Fill in about 10 liters of water into the salt supply chambers (2), however to the ribbed intermediate bottoms (3) at the maximum.
2. Put the regeneration salt blocks into the salt supply chambers (2). When arranged correctly (figure 1), 4 layers with 4 Broxo blocks a 2.5 kg/5,5 pds each (= 40 kg/88 pds) can be placed. Should there be no block salt available at the moment, pellets or coarse grained salt (7 - 15 mm/0,28 - 0,6 inch) can be filled in as well. However, the quality has to correspond to DIN 19604 in any case.
We recommend the use of clean block salt
When salt of another quality is used, the brine tank (4) has to be cleaned and the suction control at the suction screen (17) to be exchanged at shorter intervals.
3. Loosen the four fastening screws at the covering hood and remove the covering hood.
4. Enter the fitting date on the label on the left filter cell provided to this end.
5. Adjust the adjusting lever (7) for the natural water hardness (°dH) on the scale (8) to the natural water hardness available at the fitting location - at variable height to the higher value.
6. Plug power supply unit (5) into socket.
7. Open water supply (or by-pass valve 6).

Caution! The BioQuell-K has to be **vented immediately** on connection to the water mains (by-pass valve in operating position). This is automatically effected with the first regeneration as per section 8.

8. Release regeneration manually by pressing the regeneration key (12). The correct function of the device is checked as described in section „Maintenance 3 - 7“, afterwards the BioQuell-K is operational.

9. Turn the adjusting screw (9) for water down (addition of calcareous water) in a way as to enable the water to have the desired hardness after passing through the softener-usually about 8° dH. The hardness of the water is measured by a hardness tester (order no. 8742120).

Turning clockwise (screwing in):
More softened mixed water

Turning anticlockwise (unscrewing):
More calcareous mixed water

With medium natural water hardness, 1 turn corresponds to approximately 1° of change of the mixed water hardness. The test water for measuring and adjusting the water hardness can be taken from the tap „W“ (8) of the single-lever by-pass valve or at the water tap behind the softener. The test water will only then be taken from the running water when it is made sure that the newly adjusted mixed water has reached the water tap from the softener. In order to carry out a correct comparison of the test values, take the samples with normal water passage (1 tap completely opened) without consuming water at another place.

According to the **Trinkwasserverordnung** (TrinkwV) (Drinking Water Regulation) of 22nd May 1986, the limit value for sodium in drinking water is 150 mg/l. This does c., 14. not apply to mineral and table water which partly contain more than 1000 mg sodium per liter.

Whether the mixed water still corresponds to the TrinkwV as far as the sodium content is concerned, can be calculated as follows:

°dH	natural water hardness (consult the waterworks or measure by means of the hardness tester)
-	°dH mixed water hardness (test value)
=	°dH x 8.2 mg Na/°dH (Sodium ion exchange value)
=	mg/l Increase of sodium content because of softening
+	mg/l Sodium already available in natural water (consult the waterworks)
=	mg/l Total sodium content in mixed water
Example:	
-	20° dH 8° dH
=	12°dHx8.2
=	98 mg/l because of softening
+	10 mg/l from the waterworks
=	108 mg/l total

If the calculated total sodium content exceeds the admissible value of 150 mg/l of the TrinkwV, this can be corrected by adjusting the mixed water hardness to a higher value (see commissioning 9).

Operation

As the BioQuell-K works automatically, salt has only to be refilled from time to time.

If a red label indicating that salt is missing (14) appears on the left or the right below the covering hood, a complete 10 kg clean block salt block package (4 units of 2.5 kg/ 5,5 lbs) can be filled into the corresponding salt supply chamber (2). If only a small quantity of or no softened water is consumed, the BioQuell-K automatically carries out an additional regeneration every fourth day as per DIN 19636 (DVGW test guideline) for hygienic reasons.

Maintenance

The mixed water hardness should be checked at certain intervals. We recommend to use the JUDO hardness tester type JGHP (order no. 8742120).

An exact control of the function of the device can be carried out as follows (maintenance report see separate sheet).

1. After loosening the 4 fastening screws, the covering hood can be removed.

2. If no regeneration is carried out at the moment, regeneration can be released by pressing the regeneration key (12). The sterilisation display (12) lights up as soon as the generation of chlorine for the disinfection of the exchanger mass begins.
3. At first, the tank which is in a waiting position is rinsed from below to above. If the rinsing water quantity is collected in buckets with liter scale at the sewage hose (16), this allows to verify if the rinsing water quantity is about 10 liters. The rinsing time is about 3 to 7 minutes depending on the water pressure.
Caution: The excess regeneration salt is removed from the filter cells with the sewage water. It is therefore not to be used for watering of plants or the like.
4. At the same time, water is refilled into the salt tank.
5. Afterwards, a short rinsing is effected from above to below (first filtrate). The water quantity which is drained off from the sewage hose (16) is about 3 liters/0,8 US gallons.
6. For a short time, both tanks operate in parallel, then the main valves of the exhausted tank close.
7. After a short switching over time, the salting with subsequent washing starts. Depending on the water pressure, this procedure takes about 30 to 50 minutes. The brine quantity draining off the sewage hose is 5 to 9 liters (1,32 – 2,37 US gallons). The suction control (17) allows to check whether brine is suctioned. If the suction display pin is still below, no suction takes place. If it is situated above the flat underpressure area, brine is suctioned or washed out.
8. While brine is suctioned, the two electrodes in the brine tank generate a small quantity of chlorine for disinfection. After about 600 dual regenerations, to be seen at the roller type counter of the water meter (10), the electrodes and the suction control sleeve with suction screen and suction display (17) as well as the float valve gasket in the brine tank have to be replaced at the next maintenance. If the other tank has to be checked in the same way, the manual release key (12) has again to be pressed.
The same procedure as described in 3 to 8 is again effected, however on the other side of the softener.

Interruption of operation

If the water supply to the BioQuell-K is interrupted (main cock closed or by-pass opened), the power supply units of the softener and - also of the dosing pump, if available - have to be disconnected from the mains.

If a demounted softener is flanged on again and put into operation, a manual regeneration has to be started in principle in order to vent the unit.

Malfunction

If a malfunction of the unit occurs, this is indicated by an uninterrupted beep. This may also happen after a power failure. In this case, pull the mains plug out for about 5 seconds, then put it in again. Only if the beep occurs again after about 4 hours, there is a real malfunction and the after-sales service has to be informed.

Cleaning

The outer surfaces of the BioQuell-K can be cleaned with a commercial soap cleaner (soft soap). Solvents, cleaners with alcohol and varnish affect the durability of the synthetic parts (risk of breaking) and have therefore to be kept away.

The suction screen in the suction control can be cleaned by means of backwashing by unscrewing the entire suction control (17) from the unit, taking off the suction hose and by passing through a strong jet of water from above to below after removing the suction display valve.

Caution:

Prior to demounting the suction control sleeve, the water supply has to be interrupted (closed) or the JUDO-Quickset-X switched to by-pass.

In order to be able to carry out **easy cleaning** of the salt supply tank as well as the brine tank from time to time, they can be easily detached from the wall mounting:

1. Remove covering hood after loosening the 4 fastening screws.
2. Remove unsolved salt blocks from the supply chambers (2).
3. Detach filling and suction hose with suction control sleeve (15 and 17) from the control head (Figure 1).
4. Lift salt lack flaps (14).
5. Unlock brine tank (4) on the left and the right, pull it up and hinge it into the salt lack recesses.
6. Unlatch the brine tank cover at the center back and lift it off from the brine tank together with the float, the electrodes and the hoses.
7. Unscrew the locking screw (20) at the back of the unit (Figure 3).
8. Unscrew nut of the salt supply tank holding hook (21) and unhinge hook.
9. Pull salt supply tank with brine tank from the wall mounting to the front and take it near a floor drain or similar for convenient rinsing. The brine tank (4) can now entirely be taken out of the salt tank (when reinserting, please see to close fit of the vertical guide rails on the left and the right!)

The softener with the filter cells (1) remains at the tubing during the entire procedure.

Water supply is not interrupted, only the mains supply unit (5) should be disconnected in order to avoid any unintentional release of the regeneration.

Protective measures against corrosion

In all cases where 0-concentrated water passes through tubings, plastic pipes or other corrosion-resistant pipes have to be laid. In case of a partial softening (about 8° dH), galvanized and copperplated pipes can be used. It is recommendable, however, to interlock a JUDO-JULIA dosing pump into the mixed water pipe after the BioQuell-K which supplies the water proportionally with JUL-mineral solution of type „W“ with galvanized pipes and with JUL-mineral solution of type „C“ with copperplated pipes. The JUL-mineral solution exactly contains those active components which stabilize the remaining carbonate hardness components and provide the conditions for creating a homogeneous protective layer in the subsequent piping system. They correspond to the drinking water treatment regulation as to their requested kind, quality and quantity.

Consumption of salt water and sewage water

Consumption of salt and sewage water quantity in relation to 1 m³ of mixed water of 8° dH depending on the natural water hardness.

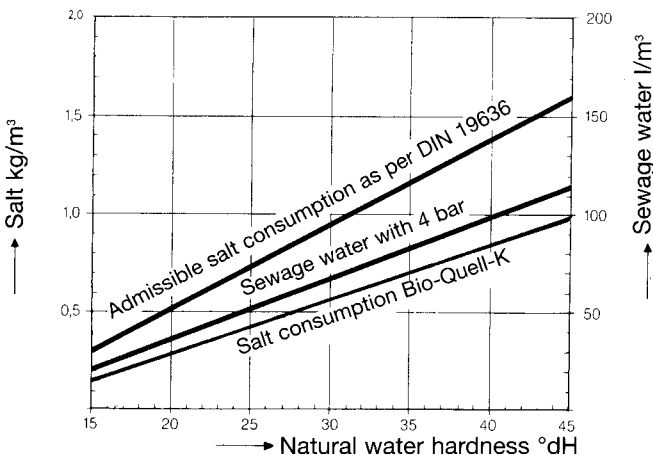

Pressure drop

Pressure drop with different natural water hardnesses and with a mixed water hardness of about 8° dH (1.5 mol/m³ sum of alkaline earths).

When a Quickset-X-single lever by-pass valve (3) is installed, the values with 2 m³/h are increased by 0.1 bar and with 3.5 m³/h by 0.3 bar.

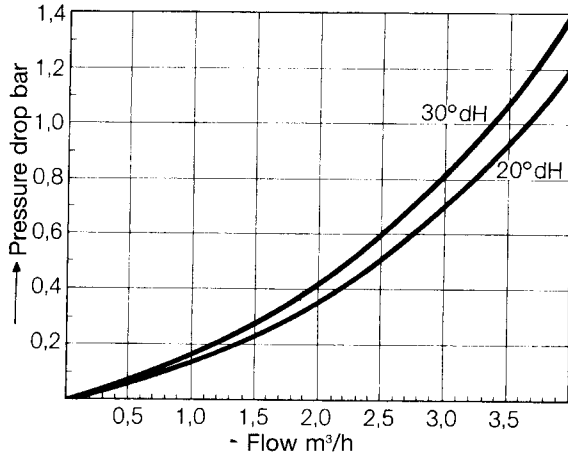

Max. possible daily tapping depending on the natural water hardness with a mixed water hardness of 8° dH and a flow pressure of 3 to 5 bar/43 – 73 psi.

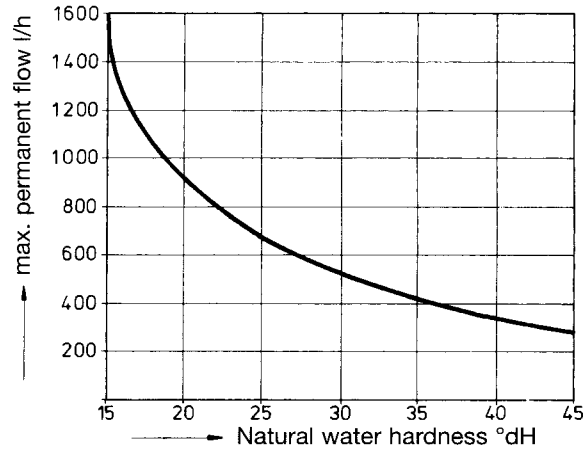

Customer service

We wish you a troublefree operation at any time. However, should any deficiencies occur or should you have any queries, our customer service will always be glad to help you. Please always state **the device number embossed on the right of the connection flange!** We urgently recommend to conclude a **maintenance agreement** so that the perfect function of all water treatment units can be checked at regular intervals.

JUDO Wasseraufbereitung GmbH
Phone Customer Service (+49-71 95) 6921 17