

Installation and Operating Instructions

JUDO PROFI

5" (DN125) -8" (DN200)

Backwash Protective Filter

Model JPF

Valid for: Canada

Attention:

Carefully read through the installation and operating instructions and safety information before installing and putting the unit into service.

These Instructions must always be issued to the owner/user.

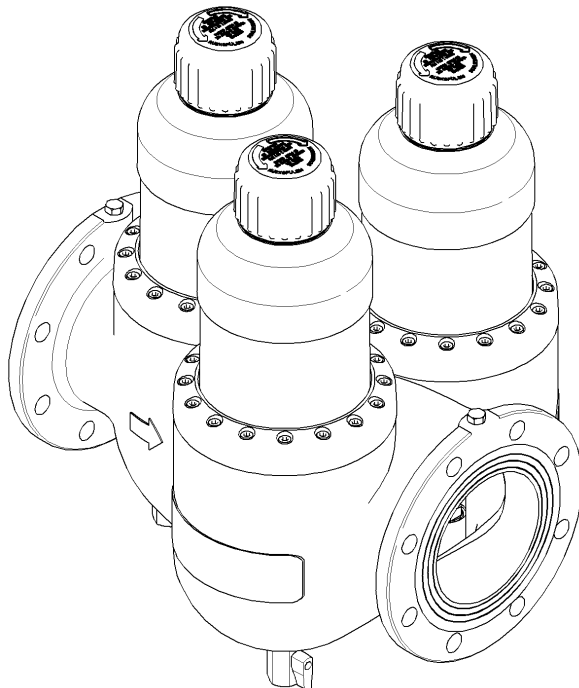

Fig. 1: JPF 7" (DN150)



Application

The Backwash Protective Filter removes all coarse and fine grained impurities which cause pitting as aeration elements in cold

and hot water supply piping, and that can lead to the malfunctioning of fittings and control- and regulation elements, as well as of sensitive devices.

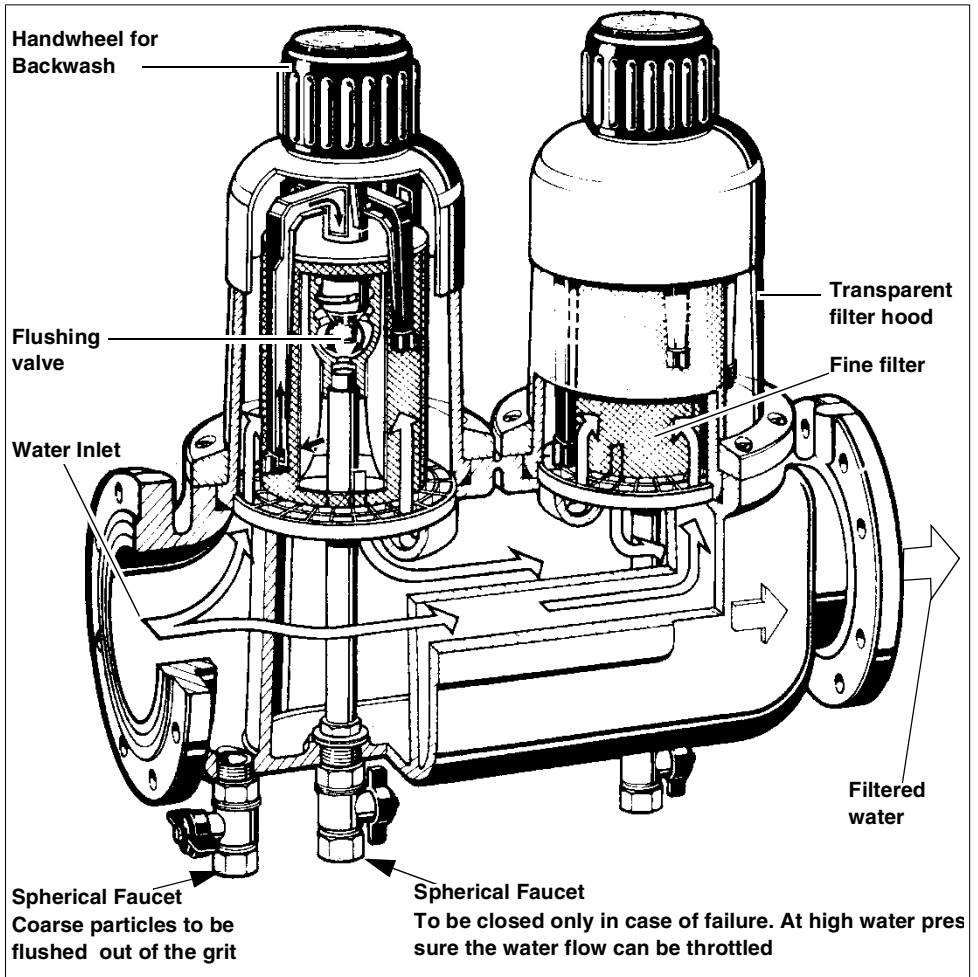

Fig. 2: Application JPF 5" (DN125) -8" (DN200)

Installation

The Backwash Protective Filter should be installed in a dry and frost resistant location with a floor drain.

It can be installed into all drinking water pipes usual in the trade, in each flow direction.

To ensure easy operation and maintenance

the indicated minimum distances have to be observed.

The installation into vertical lines should be effected only, if there isn't any possibility for an installation in horizontal lines.

If installing into a vertical line, the coarse particles, deposited in the grit trap can't be

flushed out as optimally as when installed horizontally.

Tension-free installation has to be observed!

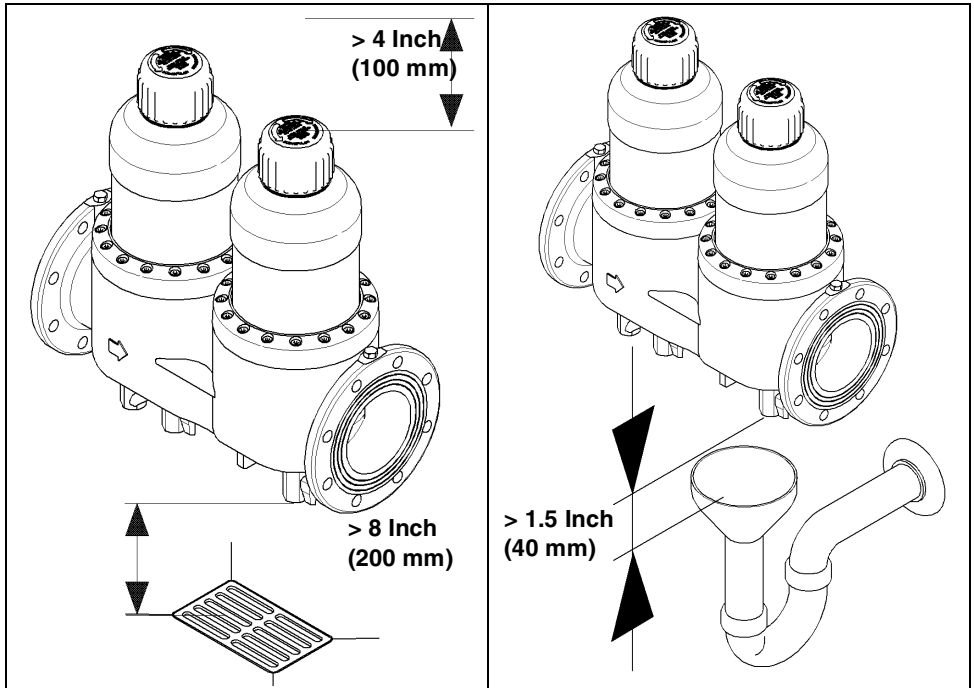

Fig. 3: Application

Example for installation

The installation of the Backwash Protective Filter is effectuated up to a water pressure of 150 psi (1000 kPa) behind the water meter, and the backflow preventer before a possibly mounted pressure reducer (see Fig. 4).

In the event of **water pressure above 150 psi (1000 kPa)**, the pressure reduction valve should be fitted **in front** of the Backwash Protective Filter (see Fig. 4). If the operating pressure is above 150 psi (1000 kPa), this may result in defects during operation.

i The installation of a pressure reduction valve is recommended for **water pressures between 73 psi (500 kPa) and 150 psi (1000 kPa)**.

For the backwashing water a wastewater connection [for example a floor drainage] in

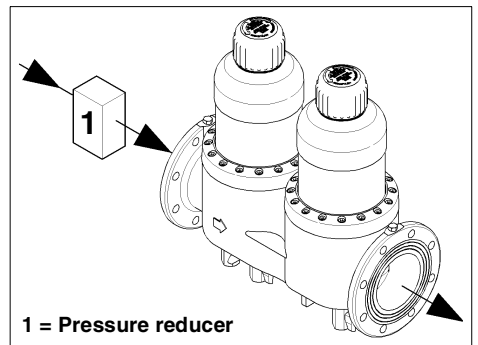

Fig. 4: Pressure reducer upstream of the unit. Example JPF 5" (DN125)

accordance with DIN 1986 must be in place. If a wastewater connection directly under the filter is not possible, the rinse water can be led by means of a line to be mounted on the rinse water valve [same dimension as the rinse water valve] a few meters away to the next wastewater connection. When pivoting a pipe for the derivation of the rinse

water it has to be paid attention to the fact that the spherical faucets are not twisted, because these are pasted in by means of thread locking devices.

Design of Backwash water connection

The dimensioning of the channel cross sections for the backwash water depends on the local conditions. For example the downward gradient of the wastewater pipe, the quantity of the detours, length of the sewage pipe.

Commissioning

Before starting up (initial putting into service or startup after maintenance work), **fill** the Backwash Protective Filter with water and **vent!**

Operation

For cleaning the filter the handwheel is untwisted to the left as far as it will go and closed to the right afterwards, till no more rinse water flows out. Rough impurities can be removed by opening the sludge trap ball valve that is built in before the backwash ball valves. According to DIN standard 1988 it is recommended to backwash the filter approximately every 2 months. Depending on the water flow as well as on the kind of coarse-grained and fine-grained impurities and the extent to which these are existing in the water, a backwashing can be necessary within shorter time intervals. The backwashing takes place at full water line pressure. At pressures higher than 2 bar, it is necessary that the backwash stream is throttled by means of the backwash ball valve. Doing this it is prevented, that the sieve cloth is damaged by a too strong pressuring of the suction tube. At the same time the rinse water consumption is reduced. With a flush valve opened to one hundred percent and a pressure between 2 bar and 3 bar the backwash volume current amounts to approx. 1 gpm (1 liter per second) concerning.

External Cleaning

Use only clear, drinking water concerning the cleaning of the housing and the transparent filter hood.

Domestic all-purpose cleaners and glass cleaners can contain up to 25% solvents or alcohol (spiritus).

These substances can chemically attack the plastic parts, which can lead to brittleness right up to [brittle] fractures.

These kinds of cleaners must therefore not be used.

Customer Service

We wish you anytime a trouble-free operation.

Should occur, however, short-comings, sometime or if there are queries, our customer service will be pleased to be at your disposal for further information.

Warranty and Services

In order to comply with the legal warranty claim, according to DIN 1988, Part 8, it is necessary that the "... backwashing takes place at least every 2 months, after operating conditions exist ...".

Furthermore an annual '....check of the set outlet pressure at the pressure gauge [visual inspection] in case of zero flow, and peak-flow [large removal].....' is required.

Regular servicing is indispensable in order to continue to achieve a successful treatment for many years after the unit is put into service. In the building services sector this is covered by DIN 1988, Part 8.

A servicing agreement is the best way to ensure a good operating function beyond the warranty period.

Wherever possible, the regular servicing work and supply with consumables and wearing materials, etc. should be carried out by the specialist trade or the factory's customer service department.

Typ

Backwash Protective Filter

JUDO PROFI 5" (DN125) -8" (DN200)

Abbreviated name:

JPF 5" (DN125) -8" (DN200)

Models

Model	Pipe connection	Order No.
JPF 5" (DN125)	DN125	8290015
JPF 6" (DN150)	DN150	8290016
JPF 8" (DN200)	DN200	8290017

Technical Data

The following applies for all the models of the device:

- Pressure loss when clean (after backwashing): 3 psi (20 kPa) at the water flow rate (nominal flow rate) given in the table.
- Maximum ambient temperature and water temperature: 86°F (30°C).
- **The water to be filtered must conform to the European Drinking Water Regulations!**
- Threaded connection to DIN 2999.
- Flange connection according to DIN 2633.

Nominal Pressure: 150 psi (1000 kPa)

Operating

Pressure: 22 - 150 psi (150 - 1000 kPa)

The nominal pressure denotes the pressure class, according to which the filter must fulfil the German requirements (DIN 19628 and DIN EN 1334-1). The maximum operating pressure is lower, in order to ensure the optimum function of the filter.

Water flow rate

Model	Water flow rate for a pressure loss of 3 psi (0.2 bar) with clean sieve insert ¹⁾
JPF 5" (DN125)	440 gpm (100 m³/h)
JPF 6" (DN150)	660 gpm (150 m³/h)
JPF 8" (DN200)	880 gpm (200 m³/h)

- 1) Data for water flow rate apply for drinking water. The maximum rate of water flow for more polluted water is smaller depending on the selected mesh width. Thus, a larger dimension shall be chosen.

Installed dimensions

All dimensions in inch (mm) (see Fig. 5)

Model	A	B	C	D	F
JPF 5" (DN125)	22.0 (560)	9.8 (250)	16.9 (430)	7.5 (191)	¾"
JPF 6" (DN150)	22.0 (560)	18.4 (468)	17.8 (453)	8.1 (207)	¾"
JPF 8" (DN200)	23.6 (600)	18.6 (474)	18.5 (469)	9.4 (238)	¾"

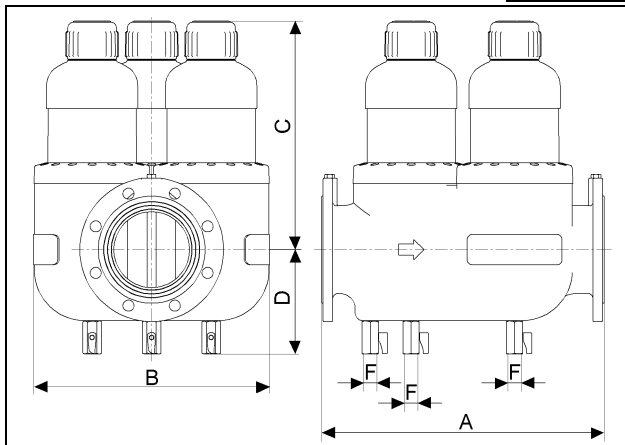

- A = Installation length
- B = unit width
- C = Height above pipe centre
- D = Height below pipe centre
- F = Connection dimension waste water

Fig. 5: Installed dimensions e.g.: JPF 6" (DN150)

Spare Parts JPF 5" (DN125) -8" (DN200)

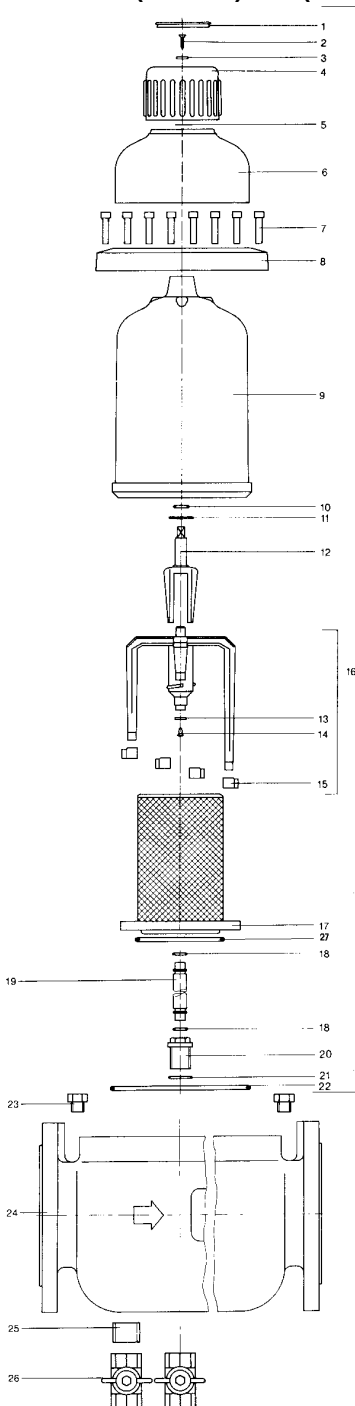

JPF 5" (DN125) two filterunits
 JPF 6" (DN150) three filterunits
 JPF 8" (DN200) four filterunits

List of Spare Parts JPF DN125-DN200

Item	Designation (Recommended average replacement interval for wearing parts [*])	Piece(s)	Order No.
1	Lid of handwheel	1	1607152
2	Countersunk screw M5x12	1	1607454
3	Disk A 6.4	1	1650142
4	Handwheel	1	1607151
5	Spacer disc	1	1120137
6	Casing top part	1	1120136
7	Cylinder Screw M8x45	16	1650208
8	Flange ring	1	2010181
9	Filter hood	****	1120129
10	O-ring 15x3.2	**	1607420
11	O-ring 28x2.5	**	1200027
12	Carrier	1	2020034
13	Suction Pipe Gasket	**	1200056
14	Plate Screw 4.2x9.5	1	1650125
15	Mouthpiece (Nozzle)	4	1120135
16	Suction Pipe complete	1	2010029
17	Filter Screen MW 0.10 mm	1	2010376
18	O-ring 12x3	2	1607110
19	Water-jet pipe JPF 5" (DN125)	1	2010060
19	Water-jet pipe JPF 6" (DN150)	1	2010061
19	Water-jet pipe JPF 8" (DN200)	1	2010062
20	Tube Connection JPF 5" (DN125)	1	2010031
20	Tube Connection JPF 6" (DN150), 8" (DN200)	1	2020265
21	O-ring 26x3	**	1607111
22	O-ring 178x3	**	1200058
23	Plug ¼"	2	2290001
24	Filter Bottom JPF 5" (DN125)	1	2010053
24	Filter Bottom JPF 6" (DN150)	1	2010056
24	Filter Bottom JPF 8" (DN200)	1	2010059
	Type Plate	2	1701778
25	Nipple	1	2010012
26	Spherical Faucet JPF 5" (DN125)	3	1610004
26	Spherical Faucet JPF 6" (DN150)	4	1610004
26	Spherical Faucet JPF 8" (DN200)	5	1610004
27	O-ring 120x1.5	2	1200124
Spare part set consisting of item. 11, 13, 14, 15, 17, 22		1	2010226

Replacement interval: ** = 2 years, **** = 4 years

Customer Service



JUDO Water Treatment Inc.

2060 Steeles Avenue. West, Unit #4

Concord, Ontario, Canada

L4K 2V1

Tel # 905-761.1555

Fax # 905-761-3335

e-mail – john.priolo@judo-watertreatment.com

Installed by:

All illustrations, dimensions and information for the different models are those valid on the date of printing. All rights are reserved for modifications as a result of technical progress or further developments. Claims with regard to models or products are excluded.