

Installation and Operating Instructions JUDO PROFI

Backwash Protective Filter DN125 - DN200

Valid for: EU countries and Switzerland

Language: English

Attention:

Carefully read through the installation and operating instructions and safety information before installing and putting the unit into service.

These must always be issued to the owner/user.

**Prolongated guarantee period
if a maintenance contract has
been concluded!**

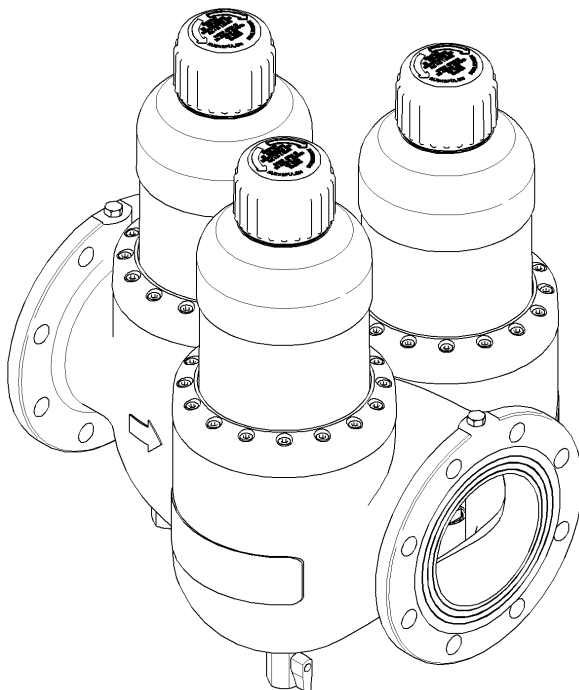

Fig.: JPF DN125 - DN200



Application

The Backwash Protective Filter removes all coarse and fine grained impurities which cause pitting as aeration elements in cold

and hot water supply piping, and that can lead to the malfunctioning of fittings and control- and regulation elements, as well as of sensitive devices.

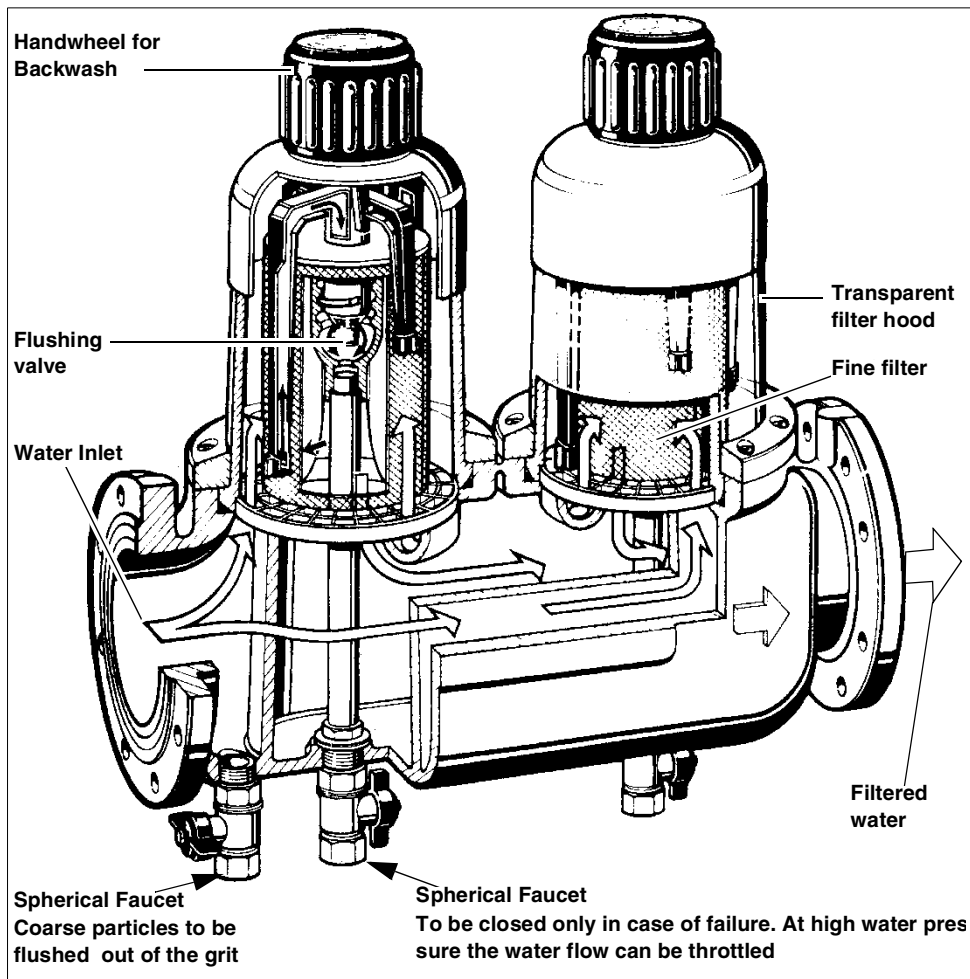

Fig. 1: Application JPF DN65-DN100

Installation

The Backwash Protective Filter should be installed in a dry and frost resistant location with a floor drain.

It can be installed into all drinking water pipes usual in the trade, in each flow direction.

To ensure easy operation and maintenance

the indicated minimum distances have to be observed.

The installation into vertical lines should be effected only, if there isn't any possibility for an installation in horizontal lines.

If installing into a vertical line, the coarse particles, deposited in the grit trap can't be

flushed out as optimally as when installed horizontally.

Tension-free installation has to be observed!

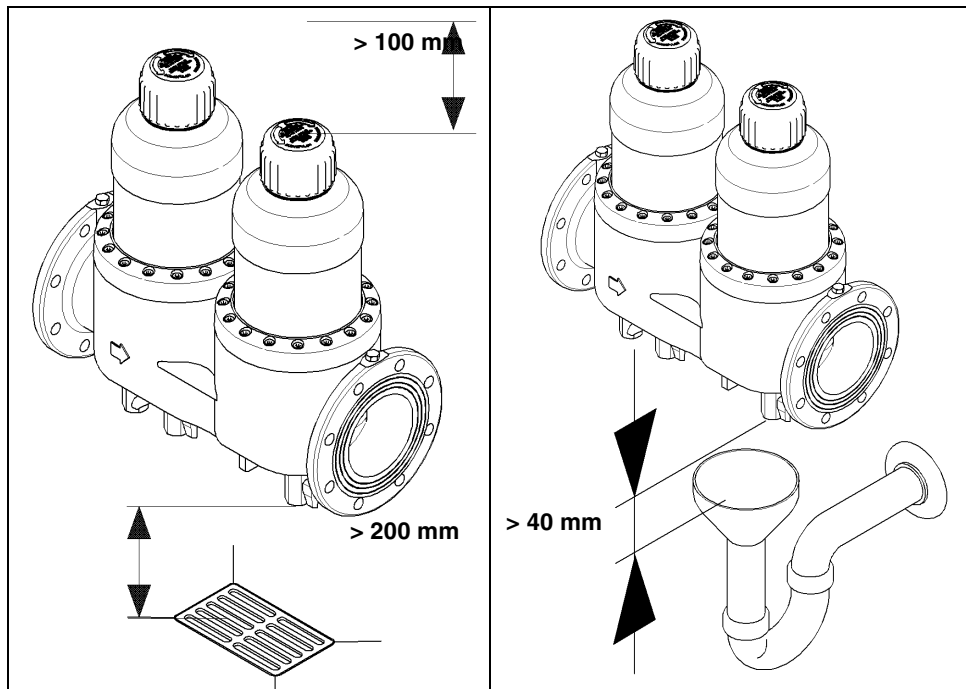

Fig. 2: Application

Installation Example

The installation of the Backwash Protective Filter is effectuated up to a water pressure of 10 bar behind the water meter, and the backflow preventer before a possibly mounted pressure reducer (see Fig. 3).

In the event of **water pressure above 10 bar**, the pressure reduction valve should be fitted **in front** of the Backwash Protective Filter (see Fig. 3). If the operating pressure is above 10 bar, this may result in defects during operation.

i We recommend the installation of a pressure reducer at a **water pressure between 5 bar and 10 bar**.

For the backwashing water a wastewater connection [for example a floor drainage] in accordance with DIN 1986 must be in place. If a wastewater connection directly under

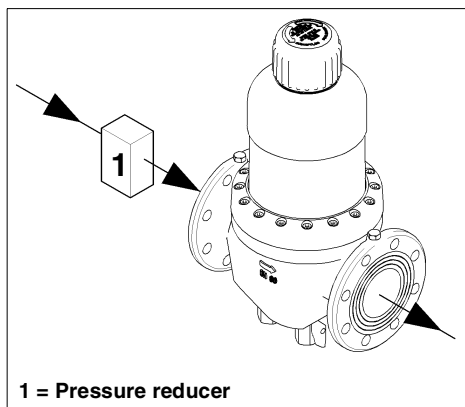

Fig. 3: Pressure reducer upstream of the unit. Example JPF DN65

the filter is not possible, the rinse water can be led by means of a line to be mounted on the rinse water valve [same dimension as the rinse water valve] a few meters away to the next wastewater connection. When piv-

oting a pipe for the derivation of the rinse water it has to be paid attention to the fact that the spherical faucets are not twisted, because these are pasted in by means of thread locking devices.

Design of Backwash water connection

The dimensioning of the channel cross sections for the backwash water depends on the local conditions. For example the downward gradient of the wastewater pipe, the quantity of the detours, length of the sewage pipe.

Commissioning

Before starting up (initial putting into service or start-up after maintenance work), **fill** the Backwash Protective Filter with water and **vent!**

Operation

For cleaning the filter the handwheel is untwisted to the left as far as it will go and closed to the right afterwards, till no more rinse water flows out. Rough impurities can be removed by opening the sludge trap ball valve that is built in before the backwash ball valves. According to DIN standard 1988 it is recommended to backwash the filter approximately every 2 months. Depending on the water flow as well as on the kind of coarse-grained and fine-grained impurities and the extent to which these are existing in the water, a backwashing can be necessary within shorter time intervals. The backwashing takes place at full water line pressure. At pressures higher than 2 bar, it is necessary that the backwash stream is throttled by means of the backwash ball valve. Doing this it is prevented, that the sieve cloth is damaged by a too strong pressuring of the suction tube. At the same time the rinse water consumption is reduced. With a flush valve opened to one hundred percent and a pressure between 2 bar and 3 bar the backwash volume current amounts to approx. 1 liters/per second concerning.

External Cleaning

Use only clear drinking water to clean the housing and transparent filter hood.

Domestic all-purpose cleaners and glass cleaners can contain up to 25% solvents or alcohol (spiritus).

These substances can chemically attack the plastic parts, which can lead to brittleness right up to a burst.

These kinds of cleaners must therefore not be used.

Customer Service

We wish you anytime a trouble-free operation.

Should occur, however, short-comings, sometime or if there are queries, our customer service will be pleased to be at your disposal for further information.

Warranty and Services

In order to comply with the legal warranty claim, according to DIN 1988, Part 8, it is necessary that the "... backwashing takes place at least every 2 months, after operating conditions exist ...".

Regular servicing is indispensable in order to continue to achieve a successful treatment for many years after the unit is put into service. In the building services sector this is covered by DIN 1988, Part 8.

A servicing agreement is the best way to ensure a good operating function beyond the warranty period.

Wherever possible, the regular servicing work and supply with consumables and wearing materials, etc. should be carried out by the specialist trade or the factory's customer service department.

Typ

Backwash Protective Filter

JUDO PROFI DN125 - DN200

Abbreviated name:

JPF DN125 - DN200

Models

Model	Pipe connection	Order No.
JPF DN125	DN125	8010035
JPF DN150	DN150	8010036
JPF DN200	DN200	8010037

Technical Data

The following applies for all the models of the device:

- Pressure loss when clean (after backwashing): 3 psi (20 kPa) at the water flow rate (nominal flow rate) given in the table.
- Maximum ambient temperature and water temperature: 30°C (86°F).
- **The water to be filtered must conform to the European Drinking Water Regulations!**
- Threaded connection to DIN 2999.
- Flange connection according to DIN 2633.

Nominal Pressure: 10 bar

Operating Pressure: 1.5 bar - 10 bar

The nominal pressure denotes the pressure class, according to which the filter must fulfil the German requirements (DIN 19632-100 and DIN EN 1334-1). The maximum operating pressure is lower, in order to ensure the optimum function of the filter.

Water flow rate

Model	Water flow rate for a pressure loss of 0.2 bar with clean sieve insert ¹⁾
JPF DN125	440 gpm (100 m ³ /h)
JPF DN150	660 gpm (150 m ³ /h)
JPF DN200	880 gpm (200 m ³ /h)

- 1) Data concerning the water flow rate are valid for drinking water. The maximum water flow rate for more polluted water is lower, depending on the mesh size. If so, a larger dimension has to be chosen.

Installed dimensions

Model	A	B	C	D	F
JPF DN125	560	250	430	191	3/4"
JPF DN150	560	468	453	207	3/4"
JPF DN200	600	474	469	238	3/4"

All dimensions in inch (mm) (see Fig. 4)

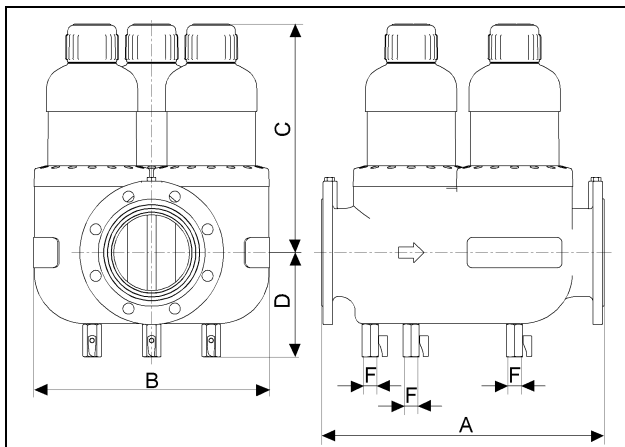
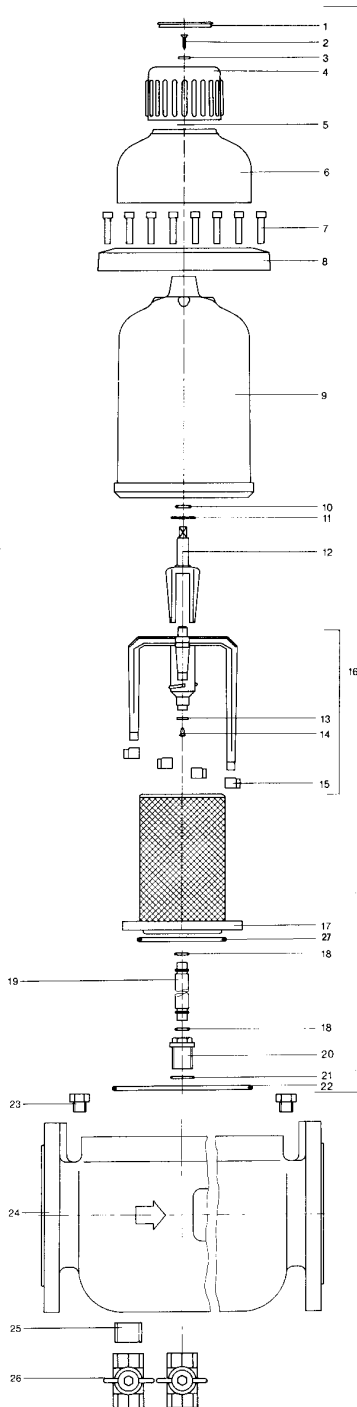

Fig. 4: Installed dimensions e.g.: JPF DN150

- A = Installation length
 B = unit width
 C = Height above pipe centre
 D = Height below pipe centre
 F = Connection dimension waste water

Spare Parts JPF DN125 - DN200



JPF DN125 two filterunits

JPF DN150 three filterunits

JPF DN125 four filterunits

List of Spare Parts JPF DN125-DN200

Item	Designation (Recommended average replacement interval for wearing parts [**])	Piece(s)	Order No.	VE ¹⁾ / Piece
1	Lid of handwheel	1	1607152	7
2	Countersunk screw M5x12	1	1607454	1
3	Disk A 6.4	1	1650142	1
4	Handwheel	1	1607151	23
5	Spacer disc	1	1120137	3
6	Casing top part	1	1120136	48
7	Cylinder Screw M8x45	16	1650208	2
8	Flange ring	1	2010181	180
9	Filter hood	****	1120129	590
10	O-ring 15x3.2	**	1607420	3
11	O-ring 28x2.5	**	1200027	3
12	Carrier	1	2020034	25
13	Suction Pipe Gasket	**	1200056	12
14	Plate Screw 4.2x9.5	1	1650125	1
15	Mouthpiece (Nozzle)	4	1120135	11
16	Suction Pipe complete	1	2010029	320
17	Filter Screen MW 0.10 mm silver plated	***	2010028	350
18	O-ring 12x3	2	1607110	2
19	Water-jet pipe JPF DN125	1	2010060	23
19	Water-jet pipe JPF DN150	1	2010061	25
19	Water-jet pipe JPF DN200	1	2010062	27
20	Tube Connection JPF DN125	1	2010031	38
20	Tube Connection JPF DN150, DN200	1	2020265	40
21	O-ring 26x3	**	1607111	8
22	O-ring 178x3	**	1200058	16
23	Plug ¼"	2	2290001	12
24	Filter Bottom JPF DN125	1	2010053	3800
24	Filter Bottom JPF DN150	1	2010056	6100
24	Filter Bottom JPF DN200	1	2010059	7200
25	Nipple	1	2010012	19
26	Spherical Faucet JPF DN125	3	1610004	32
26	Spherical Faucet JPF DN150	4	1610004	32
26	Spherical Faucet JPF DN200	5	1610004	32
27	O-ring 120x1.5	2	1200124	3
	Spare part set consisting of item. 11, 13, 14, 15, 17, 22	1	2010226	420

1) VE = Unit of Billing
Replacement interval: ** = 2 years, *** = 3 years, **** = 4 years
Extended warranty period if a maintenance agreement is concluded!

Customer Service



JUDO Wasseraufbereitung GmbH

Postfach 380 • D-71351 Winnenden
Tel. +49 (0)71 95 / 6 92-0 • Fax: +49 (0)71 95 / 6 92-188
e-mail: info@judo.eu • www.judo.eu



JUDO Wasseraufbereitung GmbH • Niederlassung Österreich

Zur Schleuse 5 • A-2000 Stockerau
Tel. +43 (0)22 66 / 6 40 78 • Fax +43 (0)22 66 / 6 40 79
e-mail: info@judo-online.at • www.judo-online.at



JUDO Wasseraufbereitung GmbH • Filiaal / Filiale BeNeLux

Avenue du Laerbeek - laan, 72 A1 • B-1090 Brussel / Bruxelles
Tel. +32 (0)24 60 12 88 • Fax +32 (0)24 61 18 85
e-mail: info@judo-online.be • www.judo.eu



JUDO France S.à.r.L

76 Rue de la Plaine des Bouchers (Technosud) • F-67100 Strasbourg
Tel. +33 (0)3 88 65 93 94 • Fax +33 (0)3 88 65 98 49
e-mail: info@judo.fr • www.judo.fr

Installed by:

All illustrations, dimensions and information for the different models are those valid on the date of printing. All rights are reserved for modifications as a result of technical progress or further developments. Claims with regard to models or products are excluded.

1701803 • 2007/03