

Installation and Operating Instructions JUDO EASY FILT- B

Backwash Protective Filter $\frac{3}{4}$ " – $1\frac{1}{4}$ "

Language: English

Attention:

Carefully read through the installation and operating instructions and safety information before installing and putting the unit into service.

These must always be issued to the owner/user.

**Prolongated guarantee period
if a maintenance contract has
been concluded!**

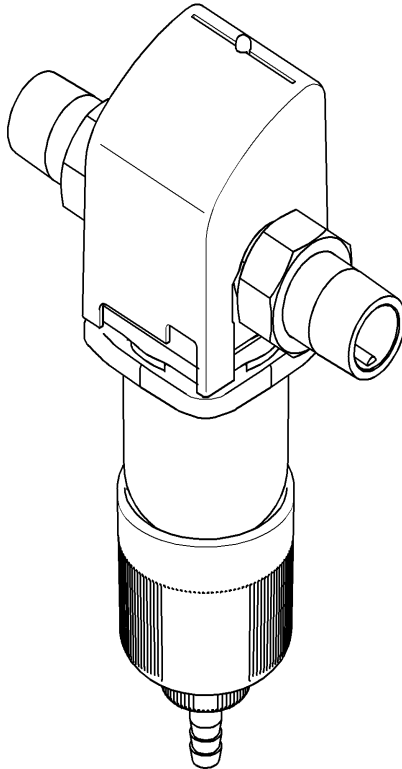

Fig.: JEF-B $\frac{3}{4}$ " – $1\frac{1}{4}$ "



Inquiries, orders, customer support

JUDO Wasseraufbereitung GmbH

P.O. Box 380

D-71351 Winnenden

e-mail: info@judo.eu

www.judo.eu

Address

JUDO Wasseraufbereitung GmbH

Hohreuschstraße 39-41

D-71364 Winnenden

Dear Customer,

we would like to thank you for your confidence in us, which you have shown by purchasing this device. The product you have purchased is a filter developed using state of the art technology.

This filter is suitable for use in cold drinking water up to a maximum ambient temperature of 30 °C (86 °F).

It removes coarse and fine-grained particles larger or equal in size to the filter screen (strainer) mesh from the filter through screen filtration.

Particles smaller than the screen mesh size used, turbidities (i. e. substances that make the water turbid) and substances dissolved in the water cannot be filtered out of the water.

Each unit is thoroughly checked before delivery. Nevertheless, should difficulties occur, please contact the responsible customer service (see back page).

Trademarks:

Trademarks used in this document are protected and registered trademarks of the respective holder.

© JUDO Wasseraufbereitung GmbH

D-71364 Winnenden

All rights reserved.

Reprints – even of extracts – is only permitted with special approval.

Table of Contents

1. About this instruction manual..... 3

 1.1 Symbols used..... 4

 1.2 Safety information and dangers due to non-compliance 4

 1.3 Units used..... 4

2. Intended use 5

 2.1 Water pressure 6

 2.2 Notes on special dangers 6

3. Product information 7

 3.1 Intended purpose..... 7

 3.2 Materials used 7

4. Installation 8

 4.1 General..... 8

 4.2 Discharging the backwashing water 10

5. Operation 11

 5.1 Commissioning 11

 5.2 Functional description..... 11

 5.3 Backwashing 12

 5.4 Modifications / changes / spare parts..... 13

 5.5 Stoppages 13

6. Faults 14

7. Maintenance..... 15

 7.1 Cleaning 15

8. Warranty and Services..... 15

9. Data sheet 16

 9.1 Type..... 16

 9.2 Models 16

 9.3 Technical data 16

 9.4 Installation dimensions JEF-B ¾" - 1¼" 17

 9.5 Extent of supply 17

10. Spare parts JEF-B ¾" – 1¼" 18

11. Customer Service 20

1. About this instruction manual



(see chapter “Safety information and dangers due to non-compliance”)

The instruction manual must permanently be available at the place where the filter is used.

This instruction manual is intended to make it easier to familiarize yourself with the filter and its possible intended uses.

The instruction manual contains important information in order to safely, properly and economically run the filter.

It contains fundamental information, which must be observed during installation, operation and maintenance. Observance of this information helps to avoid dangers, reduce repair costs and increase the reliability and service life of the filter.

The instruction manual must be read and used by each person entrusted with carrying out work on the filter, for example:

- **installation**
- **operation**
- **maintenance**
(servicing, inspection, repair)

Installation and maintenance may only be carried out by personnel authorized by the manufacturer, who are capable of fulfilling the instructions given in the installation and operating instructions and the country-specific regulations.

Apart from the instruction manual and the legally binding accident prevention provisions applicable in the country and place of use, the recognized technical regulations for safe and proper work must also be observed.

Therefore, this instruction manual must always be read by the fitter and responsible skilled personnel/owner or operator before installation, putting into service and maintenance.

Not only the general safety notes given in the chapter “Intended use” are to be observed, but also the special safety notes in the other main chapters.

1.1 Symbols used

The safety notes contained in this instruction manual are labelled with the following symbols:

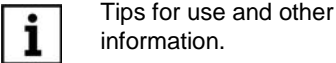
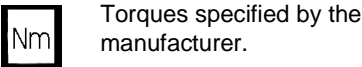
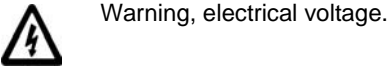

Notes directly attached to the filter, e.g.

- direction of flow (see fig. 1)
- rating plate
- cleaning information

must always be observed and kept in a fully legible condition.

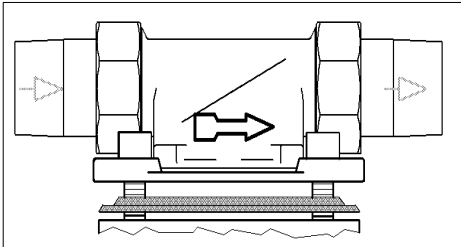

Fig. 1: Built-in rotary flange

1.2 Safety information and dangers due to non-compliance

In detail, failure to observe the general danger symbols can result, for example, in the following risks:

- failure of important functions of the filter.
- danger to persons due to electrical and mechanical effects.
- danger to persons and the environment due to leaks.

Refrain from any unsafe working methods.

Failure to comply with this instruction manual and the safety information can not only result in dangers for people but can also harm the environment and the unit.

1.3 Units used

In derogation of the International System of Units (SI = System International), the following units are used:

Units	Conversion
°F	°F = 9/5 °C + 32
bar	1 bar = 10 ⁵ Pa = 0,1 N/mm ²
¾"	DN 20
1"	DN 25
1¼"	DN 32

2. Intended use

The installation and operation of the filter is subject to the following existing national regulations.

In addition to the operating instructions and the obliging regulations concerning accident prevention that exist in the country of operation and the location of use, the established technical regulations concerning safe and professional work, should also be observed.

The water which is to be treated should fulfil the requirements stipulated by European drinking water directives!

It is absolutely essential that the manufacturer / supplier will be consulted prior to any operation of the device using water of a different quality, respectively with water that contains additives.

This filter is suitable for use in cold drinking water up to a maximum ambient temperature of 30 °C (86 °F).

The filter has been developed and manufactured using state of the art technology and the established safety regulations in Germany.

The filter may only be operated in accordance with the manufacturer's specifications. Any other operation or operation beyond the specified use, is not in accordance with the manufacturer's specifications.

Additional dangers may result in the event of the device not being operated in accordance with the manufacturer's specifications and non-observance of the danger symbols or safety instructions. The manufacturer / supplier cannot be made liable for any damages caused by these additional dangers. The operator is responsible for these risks.

The use of the device in accordance with the customer's specifications includes the observance of the operating instructions.

The manufacturer/supplier should be consulted prior to any operation of the filter other than in the operational areas stated in these operating instructions.

The filter may only be operated in a technically faultless condition, in accordance with the manufacturer's specifications and the stated safety and danger relevant instructions and under observance of the operating instructions!

Any functional defects are to be removed immediately!

2.1 Water pressure

The water pressure should be between 1.5 bar and 10 bar.

The water pressure must not exceed 1.5 bar as otherwise the backwashing can be impaired! If the filter is not backwashed regularly a pressure loss can result and this can impair the filter function.



ATTENTION

(see chapter "Safety information and dangers due to non-compliance")

In the event of **water pressure above 10 bar**, the pressure reduction valve should be fitted **in front** of the filter (see fig. 2). If the operating pressure is above 10 bar, this may result in defects during operation.

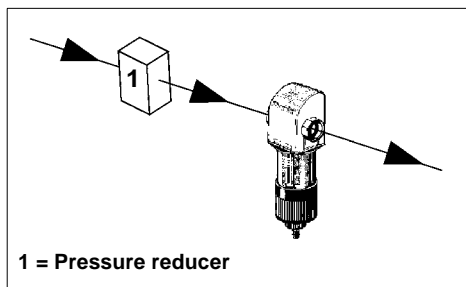

Fig. 2: Pressure reducer upstream of the unit



The installation of a pressure reduction valve is recommended for **water pressures between 5 bar and 10 bar**.

2.2 Notes on special dangers

2.2.1 Electrical equipment / installations



There must not be any electrical cables and devices underneath or in the immediate vicinity of the filter!

Electrical devices / equipment that are not splash-water proof and are situated in the direct vicinity of the filter may be damaged by water leaking from the filter caused as a result of the device not being operated in accordance with the manufacturer's specifications.

In addition this may also result short circuits if these electrical devices / equipment being connected to the electrical power supply. In the event of such cases persons are at risk and may sustain electrical shocks. Therefore any electrical devices / equipment situated in the direct vicinity should be splash-water proof, respectively comply with the statutory requirements for wet areas (IP44).

3. Product information

3.1 Intended purpose

This filter is suitable for use in cold drinking water up to a water temperature of maximum 30 °C (86 °F).



ATTENTION

(see chapter “Safety information and dangers due to non-compliance”)

Please refer to the chapter on “Intended use” for use restrictions.

This filter removes coarse and fine-grained particles from the water which are larger than or equal in size to the mesh size of the filter.



Particles smaller than the supplied mesh size and impurities causing turbidity cannot be filtered out of the water.

3.2 Materials used

The materials used are resistant to the physical, chemical, and corrosive loads to be expected in the drinking water and fulfil the requirements specified in the DIN EN 13443-1 and DIN 19628 standards (“Mechanical filters in drinking water installations”). All materials are hygienically and physiologically safe. Plastics fulfil the official guideline of the German Federal Environmental Agency as well as the DVGW work sheet W270. Metallic materials fulfil the requirements of the DIN 50930-6 standard (Impact on the drinking water quality).

4. Installation

4.1 General



(see chapter “Safety information and dangers due to non-compliance”)

The unit may only be installed by skilled personnel.

The chapter “Intended use” must always be observed!

The pipes must be able to safely support the filter.

Otherwise mechanical damage or fractures/ bursts can occur in the pipes. This can result in major water damage. People close to the filter are exposed to a health risk due to the large quantities of water released. Therefore, if necessary, the pipes must be additionally fixed or supported.

A space of at least 200 mm should be maintained above and below the filter. These distances are necessary to be able to properly carry out the backwashing (see chapter “Discharging the backwashing water”).

4.1.1 Requirements for the place of installation

The room where the unit is installed must be dry and frost free!

Unauthorised persons must not have access to the filter!



(see chapter “Safety information and dangers due to non-compliance”)

- The ambient temperature must not exceed 30 °C (86 °F)! At higher temperatures or direct sun radiation the material can be damaged and the filter hood can even break.
- In order to be able to safely discharge the wastewater in operation and in case of any defects that occur in the system, precise compliance with the details given in the “Installation” chapter is necessary! If the wastewater (backwashing) cannot be safely and completely discharged, the house and installations can be damaged by water.
- A shut-off valve must be installed upstream of the filter! This enables the water supply to the filter to be interrupted during installation, servicing/maintenance, repairs and in case of malfunctions. Floods and serious water damage to house installations can therefore be avoided.
- The unit can be installed in all standard drinking water pipes.
- It is not permitted to install the filter **upstream of** the water meter!

4.1.2 Installation position



(see chapter “Safety information and dangers due to non-compliance”)

Always install the filter in a vertical position ($\pm 5^\circ$)!

Failure to observe this can cause uncontrolled backwashing water to escape and can result in damage caused by water.

4.1.3 Mounting the built-in rotary flanges

Install using the supplied built-in rotary flange. The built-in rotary flange is used as a connecting element between the pipe and the filter.

It is suitable for both horizontal and vertical pipes.

The built-in rotary flange must be installed in the direction of flow. This is marked by a cast in arrow.

Failure to comply with this means the filter cannot work.



(see chapter “Safety information and dangers due to non-compliance”)

The flange surface of the built-in rotary flange must be in a horizontal position! The built-in rotary flange must be fitted so that mechanical stresses cannot occur! Otherwise mechanical damage can result in the built-in rotary flange. Otherwise mechanical damage can result, the pipe may burst or the built-in rotary flange can break. This can result in major water damage.

In this case, people close to the filter are exposed to a health risk due to the large quantities of water.

Therefore, during installation, ensure that no large forces act on the pipe, built-in rotary flange and filter.

4.1.4 Installing the filter



Select the torque (approx. 4 Nm) so that the gasket closes and the filter is not damaged or strained!

The filter is connected using the supplied built-in rotary flange. It consists of the built-in rotary flange and profiled flange seal.

Undo the built-in rotary flange union nuts and fit to the pipe with the sleeve.

Note the installed dimensions!

Position the filter with pre-fitted built-in rotary flange between the sleeves, insert the flat seals and screw using the union nut.

The cast in arrow of the built-in rotary flange must match the direction of flow of the water.



(see chapter “Safety information and dangers due to non-compliance”)

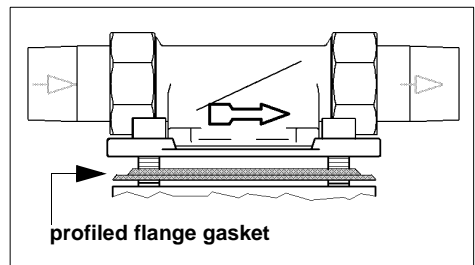

Fig. 3: Profiled flange gasket

The section of the profiled flange gasket must point towards the built-in rotary flange. Failure to observe this can lead to leaks and water escaping. This can in turn cause water damage to the house and its installations (see fig. 3).

4.2 Discharging the backwashing water



ATTENTION

(see chapter "Safety information and dangers due to non-compliance")

An adequately dimensioned wastewater connection (e.g. floor drain) to DIN 1986 must be available for the backwashing water. If there is no wastewater connection an appropriately sized bucket can be used.

The dimensioning depends on the local circumstances (e.g. wastewater pipe gradient, number of pipe bends, length of the wastewater pipe, etc.). The dimensioning must at least allow all the wastewater to be discharged at the same time. If it is not possible to provide a wastewater connection directly beneath the filter, the flushing water can be fed several metres to the next wastewater connection, either through a hose or a pipe to be fitted to the flushing water valve. This pipe must have the same dimension as the flushing water valve.

In all options, a free discharge must be ensured in accordance with EN 1717.

The following points must be noted if a bucket is used for backwashing:

- If the mains pressure is high, water can splash out of the bucket. In this case, damage to property close to the filter is possible.
- When the bucket is half-filled the backwashing process must be stopped. Otherwise it is possible for the bucket to overflow. Therefore the bucket must be adequately dimensioned and the backwashing should be carried out quickly.

4.2.1 Backwashing water discharge options

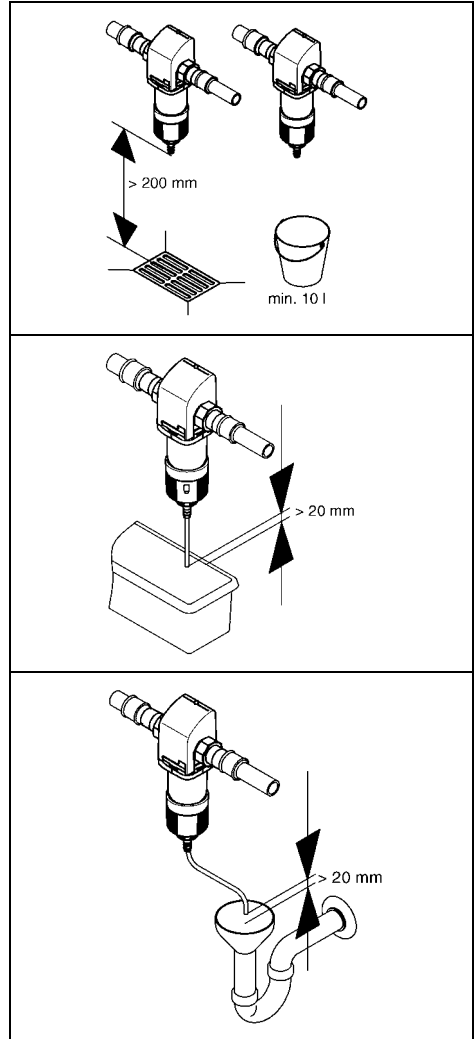

Fig. 4: Backwashing water discharge options

5. Operation



ATTENTION

(see chapter "Safety information and dangers due to non-compliance")

Always observe the chapter "Intended use"!

5.1 Commissioning

Before starting up (initial putting into service or startup after maintenance work), **fill** the filter station with water and **vent!**

- To this end, after installation the filter station is filled with water by opening the upstream shut-off valve.
- The filter is now at the same pressure as the water system.
- The enclosed air must then be immediately removed from the filter station in order to avoid damage to the installation caused by pressure surges. The filter station is vented by means of backwashing (see chapter "Discharging the backwashing water").
- After backwashing and venting the filter station is ready for use.

5.2 Functional description

Water flows through the built-in rotary flange (1) into the filter. The water flows through the fine filter from the outside inwards. The filtered dirt is retained by the fine filter screen. The adhering dirt is visible through the transparent filter cover (5). The filtered water then leaves the filter via the built-in rotary flange (1).

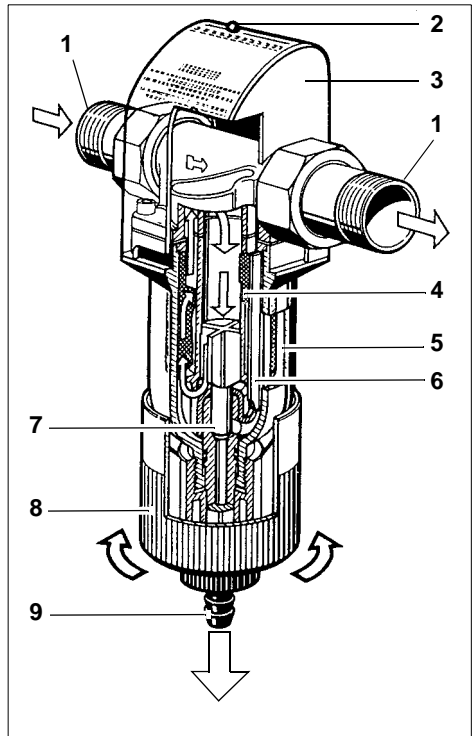

Fig. 5: Functional description

- 1 built-in rotary flange
- 2 display button
- 3 cover
- 4 strainer
- 5 filter bell
- 6 Suction Pipe
- 7 flushing valve
- 8 handwheel for free discharge
- 9 rotatable hose connection for backwashing water

5.3 Backwashing

The filter must be backwashed (=cleaned) at the specified cycles in order to remove the filtered dirt from the fine filter screen.



All sizes of filter are backwashed with treated water. The supply of treated water to the filter station is maintained throughout the backwashing process. Dirty water cannot get into the clean water side during backwashing.

The backwashing takes place at full tap (water system) pressure.

To clean the filter, the handwheel must be turned to the left up to the limit stop, thereby opening the flushing valve. While the handwheel is being turned the flushing water escapes. The flushing valve must then be closed again by turning the handwheel to the right.

The ceramic flushing valve thus closes again and the backwashing process is completed.



Both the degree of soiling and the cleaning process can be observed from the outside.



(see chapter “Safety information and dangers due to non-compliance”)

If the locking procedure is interrupted the flushing valve is not completely closed.

Water permanently escapes as a result. Apart from high water consumption, this can also cause water damage, especially if the backwashing water is not discharged as described in the chapter “Discharging the backwashing water”.

5.3.1 Backwashing interval

The filter must be backwashed:

- Every two months at the latest.
- If the water pressure falls.
- If the filter is visibly dirty.



There is a display button on the built-in rotary flange attached to the filter. It can be slid along the months scale. This enables the backwashing interval to be monitored.



(see chapter “Safety information and dangers due to non-compliance”)

If the interval until the next backwashing is longer than two months, the particles on the filter screen can stick or a large filter pressure resistance can result.

Unauthorised persons must not operate the filter! Persons who operate the filter must observe the operating instructions. Failure to observe these instructions can result in damage to property and personal injuries.

The smaller the mesh size of the screen insert the more frequently backwashing is required!

From experience, increased dirt is deposited during the initial running period. In this case the unit will have to be flushed more frequently than normal.

Failure to flush in good time can cause damage to the screen. Large quantities of filtered particles can deform the screen. As a result, proper function of the filter is no longer ensured. In addition, large quantities of dirt can cause mechanical damage to the backwashing function.

5.4 Modifications / changes / spare parts



(see chapter "Safety information and dangers due to non-compliance")

Only original spare parts are to be used!

Independent modifications and changes are prohibited for safety reasons! These can impair the function of the filter, lead to lead and in extreme cases can cause the filter to burst.

The test marks imprinted on the unit are only valid if original spare parts are used.

5.4.1 Servicing / Repair

Before carrying out any work on the filter, which extends beyond pure operational control, the filter must be depressurised! Failure to observe this can lead to an uncontrolled escape of water and therefore lead to water damage in the building. Strictly comply with the instructions given in the "Installation" and "Maintenance" chapters.

5.5 Stoppages



(see chapter "Safety information and dangers due to non-compliance")

If a filter has to be removed from the flange or unscrewed, the chapter "Intended use" must always be observed!

- Protect the flange surfaces from damage! Damaged flange surfaces cannot close tight. As a result, escaping water can damage the building and installations.
- Ensure that no dirt can get into the filter! This dirt can get into contact with and be discharged into the drinking water when the filter is switched back on. The health of people who drink dirty water is at risk.
- Store the filter in frost-free conditions! Frost can cause any water contained in the filter voids to freeze and thus cause mechanical damage to the filter so that it leaks at operating pressure or can burst. Leaking water can cause major damage to the building. In addition, people near the filter can be injured by breaking off filter parts.
- When restarting the filter, follow the instructions for a new filter.

6. Faults

In order to ensure unit safety and leak tightness, only approved persons may open the units and replace parts subject to water pressure.

Help with faults:

Fault	Cause	Remedy
Backwashing water continues running!	Flushing valve not fully closed.	Repeat the backwashing and then turn to the right up to the limit stop of the flushing valve!
	Dirt in the flushing valve.	
Water flow rate falls!	Screen is blocked.	Carry out backwashing.
Leaks in the filter!	Filter cover has been exposed to high temperatures or solvents.	Inform the fitter or nearest customer service centre. (The filter cover must be replaced immediately.)
Filter cover becomes turbid!		
Hairline cracks on the filter hood!		

7. Maintenance



(see chapter "Safety information and dangers due to non-compliance")

Always observe the chapter "Intended use"!

7.1 Cleaning



(see chapter "Safety information and dangers due to non-compliance")

Only use clear, clean drinking water to clean the housing and transparent filter cover.

Domestic all-purpose cleaners and glass cleaners can contain up to 25% solvents or alcohol (spirits).

These substances can chemically attack the plastic parts, which can lead to brittleness or even fractures.

Such cleaners must therefore not be used.

8. Warranty and Services

In order to comply with the legal warranty claim, according to DIN 1988, Part 8, it is necessary that the "... backwashing takes place according to the existing operating conditions, at the latest, however, every two months ...".

Further, an annual "... check of the set discharge pressure at the pressure gauge (visual check) when no water is flowing and at the peak flow (large amount drawn off) ..." is necessary.

Regular servicing is indispensable in order to continue to achieve a successful process for many years after the unit is put into service. In the building services sector this is covered by DIN 1988, part 8.

A servicing agreement is the best way to ensure a good operating function beyond the warranty period.

Wherever possible, the regular servicing work and supply with consumables and wearing materials, etc. should be carried out by the specialist trade or the factory's customer service department.

9. Data sheet

9.1 Type

JUDO EASY FILT- B
Backwash Protective Filter
Abbreviated name: JEF-B

9.2 Models

Model	Order No.
JEF-B ¾"	8070646
JEF-B 1"	8070647
JEF-B 1¼"	8070648

9.3 Technical data

The following applies for all the models of the device:

- The filters are supplied with a stainless steel screen with a mesh size of 0.1 mm as a standard.
- Pressure loss when clean (after backwashing): 0.2 bar at the water flow rate (nominal flow rate) given in the table.
- Maximum ambient temperature and water temperature: 30 °C (86 °F).
- **The water to be filtered must conform to the European Drinking Water Regulations!**
- Threaded connection to ISO 7-1 und EN ISO 228-1.

Nominal pressure

Model	Operating pressure	Nominal pressure
JEF-B ¾" – 1¼"	1.5 – 10 bar	PN 16

The nominal pressure denotes the pressure class, according to which the filter must fulfil the requirements to DIN 19632. The maximum operating pressure is lower, in order to ensure the optimum function of the filter.

Weight

Model	Weight
JEF-B ¾"	1.7 kg
JEF-B 1"	1.8 kg
JEF-B 1¼"	2.2 kg

Water flow rate

Model	Water flow rate up to	Pressure loss after backwashing
JEF-B ¾"	4.1 / 6.6 m³/h	0.2 / 0.5 bar
JEF-B 1"	4.6 / 7.3 m³/h	0.2 / 0.5 bar
JEF-B 1¼"	4.9 / 7.9 m³/h	0.2 / 0.5 bar

Backflush volume stream

Model	Backflush volume stream
JEF-B ¾"	0.3 l/s
JEF-B 1"	0.3 l/s
JEF-B 1¼"	0.3 l/s

The backwashing volumetric flow given applies to 2 - 3 bar mains pressure and for a completely opened flushing water valve.

9.4 Installation dimensions

JEF-B ¾" - 1¼"

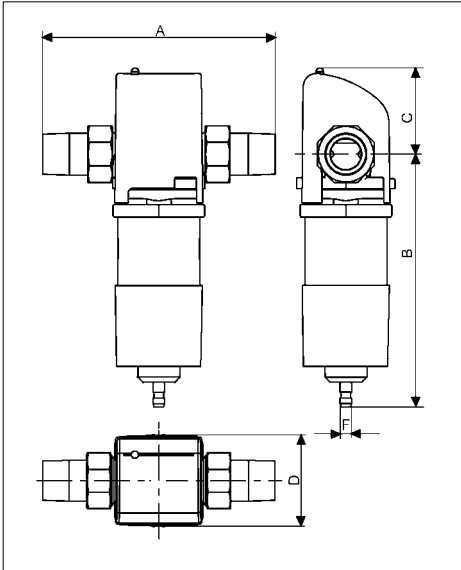

Fig. 6: Installation dimensions
JEF-B ¾" - 1¼"

Model	A	B	C	D	F
JEF-B ¾"	180	225	75	80	20
JEF-B 1"	195	225	75	80	20
JEF-B 1¼"	230	220	75	80	20

All dimensions in [mm] (see fig. 6)

A = installation length

B = height under the centre of the pipe

C = height above the centre of the pipe

D = unit width

F = connection dimension waste water

9.5 Extent of supply

- Pre-installed filter
- Installation and Operating Instructions
- Fitted rotating flange JQE ¾", 1" or 1¼" with screw connection (JEF-B ¾" – 1¼")
- Fitted rotating flange JQE 1½" or 2" with bayonet fixture and screw connection (JEF-B 1½" – 2")

10. Spare parts JEF-B 3/4" – 1 1/4"

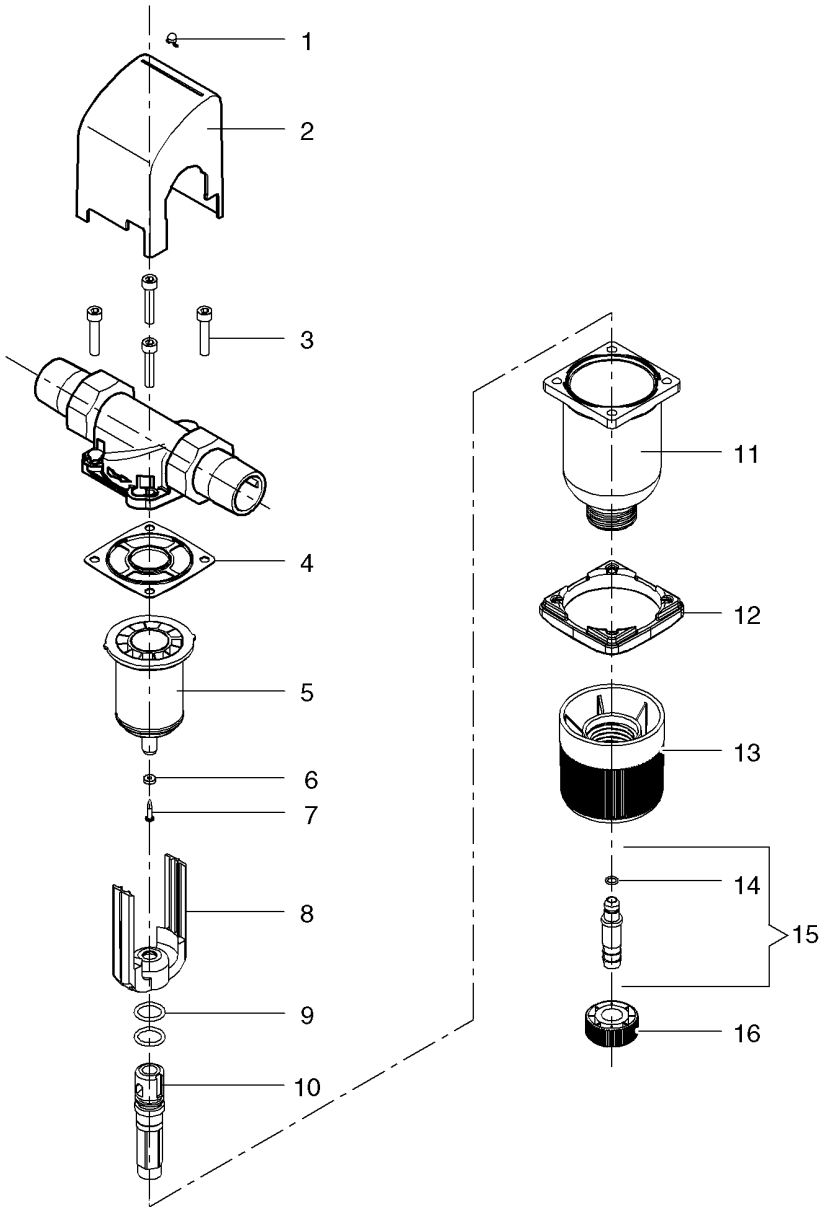

List of spare parts JEF-B ¾" – 1¼"

Pos.	Designation (recommended average replacement interval for wearable parts [*])	piece(s)	Order no.	AU ¹⁾ /piece
1	Display button	1	1120424	2
2	Cover of flange JEF-B ¾ - 1"	1	2070400	13
2	Cover of flange JEF-B 1¼"	1	2070408	13
3	Cylinder screw M6 x 30	4	1650209	2
4	Profile flange seal	** 1	1200218	5
5	Strainer	**** 1	2150015	68
6	Suction pipe gasket	**** 1	1607410	3
7	Tapping screw	1	1650173	1
8	Suction pipe	1	1120217	12
9	O-ring 16 x 2.5	**** 2	1200130	3
10	Flushing valve	1	1120212	8
11	Filter bell	1	1120309	140
12	Flange	1	1420013	20
13	Handwheel	1	1120215	20
14	O-ring 6.07 x 1.3	1	1200137	5
15	Tube connection pre-mounted	1	1120213	5
16	Union nut	1	1120214	4

1) UB = Accounting Unit

Replacement interval

** = 2 years

**** = 4 years

Extended warranty period if a maintenance agreement is concluded!

11. Customer Service



JUDO Wasseraufbereitung GmbH

Postfach 380 • D-71351 Winnenden
Tel. +49 (0) 7195/ 692- 0 • Fax: +49 (0) 7195/ 692- 110
e-mail: info@judo.eu • www.judo.eu



JUDO Wasseraufbereitung GmbH • Niederlassung Österreich

Zur Schleuse 5 • A-2000 Stockerau
Tel. +43 (0)22 66 / 6 40 78 • Fax +43 (0)22 66 / 6 40 79
e-mail: info@judo-online.at • www.judo.eu



JUDO Waterbehandeling GmbH • Filiaal / Filiale BeNeLux

Laerbeeklaan 72 A1 • 72 A1, Avenue du Laerbeek • B-1090 Brussel/Bruelles
Tel./Tél. +32 (0)24 60 12 88 • Fax +32 (0)24 61 18 85
e-mail: info.benelux@judo.eu • www.judo.eu



JUDO France S.à.r.L

76 Rue de la Plaine des Bouchers (Technosud) • F-67100 Strasbourg
Tel. +33 (0)3 88 65 93 94 • Fax +33 (0)3 88 65 98 49
e-mail: info@judo.fr • www.judo.fr

Installed by:

<p>JUDO BIostat-COMBIMAT The Anti-Lime Protection and Hygiene-Unit to be used in domestic water installations.</p>	<p>JUDO ZEWA WATER STOP Central water safety fitting. Stops water flow in the event of water pipe bursts and detects leaks.</p>	<p>JUDO Backwash Protective Filter SPEEDYMAT-LongLife Automatic Backwash Protective Filter Automatic in the long-life class with patented ceramic flushing valve backwashing technique.</p>
<p>JUDO BIOQUELL-SOFT Softening unit producing wonderfully soft water, protecting against lime and economising energy.</p>	<p>JUDO JULIA Metering pump for JUL mineral solution against corrosion (brown water) and lime deposits.</p>	<p>JUDO HEIFI-KOM Combination of the heating backwashing filter and automatic heating feed station for fulfilment of DIN EN 1717.</p>

All illustrations, dimensions and information for the different models are those valid on the date of printing. All rights are reserved for modifications as a result of technical progress or further developments. Claims with regard to models or products are excluded.

1701981 • 2010/01