

1. About this Operating Instructions5

- 1.1 Symbols used5
- 1.2 Safety information and dangers due to non-compliance6
- 1.3 Units used6

2. Intended Use7

- 2.1 Water pressure7
- 2.2 Notes on special dangers7

3. Product Information9

- 3.1 Intended purpose9
- 3.2 Test marks9
- 3.3 Materials used9

4. Installation9

- 4.1 General9
- 4.2 Requirements for the place of installation10
- 4.3 Examples for installing the water treatment devices12
- 4.4 Flush Discharge12

5. Operation14

- 5.1 Commissioning14
- 5.2 Description of its function15
- 5.3 Control lamps, manual pushbuttons17
- 5.4 Cleaning - Flushing17
- 5.5 Warning message "Battery flat"17
- 5.6 Mounting of the covers18
- 5.7 Replacing the batteries18
- 5.8 Modifications / changes / spare parts18
- 5.9 Stoppages19

6. Fault20

7. Maintenance21

- 7.1 Cleaning21

8. Warranty and Services21

9. Data Sheet22

- 9.1 Type22
- 9.2 Models22
- 9.3 Technical specifications22
- 9.4 Mounting Dimensions 23
- 9.5 Scope of supply23
- 9.6 Accessories (not included in scope of supply)23

10. Spare Parts BIostat-COMBIMAT 24

11. Customer Support28

Installation and Operating Instructions

JUDO BIOSTAT-COMBIMAT

Lime protection and hygiene centre

Valid for: UK only

FOR DOMESTIC USE ONLY

Attention:

Carefully read through the installation and operating instructions and safety information before installing and putting the unit into service.

These must always be issued to the owner/user.

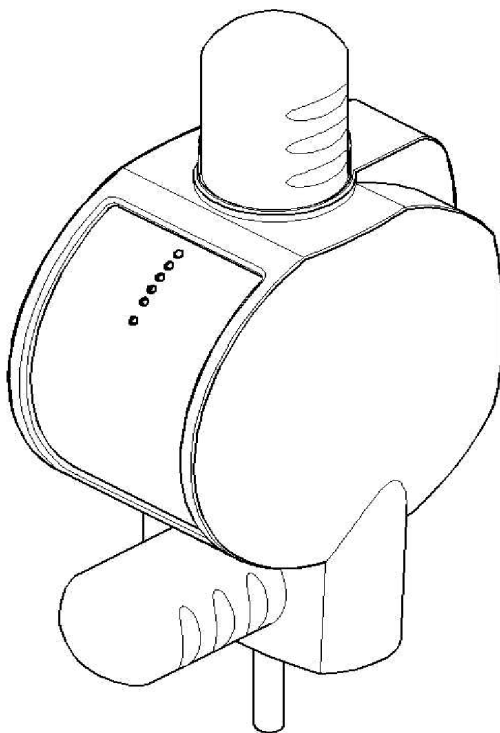

BST-CA



For protection against lime, in accordance
with DVGW-W510

JUDO
Water
Treatment



Inquiries, orders, customer support

JUDO UK Limited

The old court House,

Ascot, SL5 7EN

Phone: (44) 700 605 9441

Internet: <http://www.judo.uk.com>

Dear Customer,

thank you for making JUDO your brand of choice. With this water treatment device you have purchased an unit that corresponds fully to the most updated standards of technology.

This water treatment device is suitable for use in cold drinking water up to a maximum ambient temperature of 30 °C (86 °F).

Each unit is thoroughly checked before delivery. Should difficulties occur, please contact the responsible customer service. See back page.

Trademarks:

Trademarks used in this document are protected and registered trademarks of the respective holder.

© JUDO Wasseraufbereitung GmbH
D-71364 Winnenden

All rights reserved.
Reprints – even of extracts – is only permitted with special approval.



EC Conformity Declaration

Document no. 204/11.07

Manufacturer: JUDO Wasseraufbereitung GmbH

Address: Hohreuschstr. 39 - 41
D-71364 Winnenden

**Product Description: BIOSTAT-COMBIMAT Type 15, Type 25
Water treatment devices**

- EC-Directive: Electromagnetic Compatibility (EMC) 2004/108/EC
- Engineering Standards: Electromagnetic Compatibility, Generic Standards for Radiated Interference and Interference Immunity. EN 61000-6-2 EN 61000-6-3

The observance of all points of the EMC requirements (EC conformity) for the use of the device in household / commercial areas and industrial areas is hereby confirmed.

- Harmonized Standard: Safety of power transformers, power supply units and similar. EN 61558-1

Issuer: JUDO Wasseraufbereitung GmbH

Place and Date: Winnenden, 13 November 2007

Legally binding signature:

JUDO Wasseraufbereitung GmbH

This declaration certifies that the product is in accordance with all the stated directives; it is however not an assurance of its characteristics.

Table of Contents	8. Warranty and Services..... 21
1. About this Operating Instructions ... 5	9. Data Sheet..... 22
1.1 Symbols used 5	9.1 Type 22
1.2 Safety information and dangers due to non-compliance 6	9.2 Models..... 22
1.3 Units used..... 6	9.3 Technical specifications 22
2. Intended Use..... 7	9.4 Mounting Dimensions 23
2.1 Water pressure 7	9.5 Scope of supply..... 23
2.2 Notes on special dangers 7	9.6 Accessories (not included in scope of supply)..... 23
3. Product Information 9	10. Spare Parts BIostat-COMBIMAT. 24
3.1 Intended purpose..... 9	11. Customer Support..... 28
3.2 Test marks 9	
3.3 Materials used 9	
4. Installation 9	
4.1 General..... 9	
4.2 Requirements for the place of installation..... 10	
4.3 Examples for installing the water treatment devices 12	
4.4 Flush Discharge..... 12	
5. Operation 14	
5.1 Commissioning 14	
5.2 Description of its function 15	
5.3 Control lamps, manual pushbuttons 17	
5.4 Cleaning - Flushing..... 17	
5.5 Warning message "Battery flat". 17	
5.6 Mounting of the covers 18	
5.7 Replacing the batteries..... 18	
5.8 Modifications / changes / spare parts..... 18	
5.9 Stoppages 19	
6. Fault..... 20	
7. Maintenance..... 21	
7.1 Cleaning 21	

Unit-No.:

1. About this Operating Instructions



(see chapter “Safety information and dangers due to non-compliance”)

The instruction manual must permanently be available at the place in which the water treatment device is used.

This instruction manual is intended to make it easier to familiarize yourself with the water treatment device and its possibly intended uses.

The instruction manual contains important information on the correct, safe and economical operation of this water treatment device.

It contains fundamental information which must be observed during installation, operation and maintenance. Observance of this information helps to avoid dangers, reduce repair costs and increase the reliability and working life of the water treatment device.

The instruction manual must be read and used by each person entrusted with carrying out work on the water treatment device, for example:

- **Installation**
- **Operation**
- **Maintenance** (servicing, inspection, repair)

Installation and maintenance may only be carried out by skilled personnel authorized by the manufacturer, who are capable of fulfilling the instructions given in the installation and operating instructions as well as regulations valid in the country of use.

Apart from instructions given in this manual, all laws and regulations governing installation, health & safety in the workplace and valid in the country of use must be adhered to at all times.

Therefore, this instruction manual must always be read by the fitter and responsible skilled personnel/owner or operator before installation, commissioning and maintenance.

Not only the general safety notes given in the chapter on “Intended Use” are to be observed, but also the special safety notes inserted under the other main items.

1.1 Symbols used

The safety notes contained in this instruction manual are labelled with the following symbols:

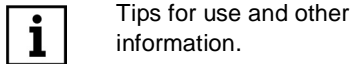
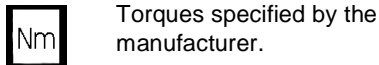
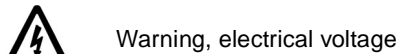

Notes directly attached to the water treatment device, e.g.:

- Direction of flow (see fig. 1)
- Type plate
- Cleaning information

must always be observed and kept in a fully legible condition.

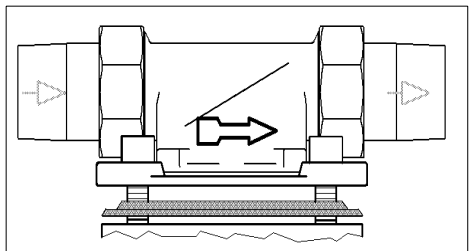

Fig. 1: Built-in rotary flange

1.2 Safety information and dangers due to non-compliance

In detail, failure to observe the general danger symbols can result, for example, in the following risks:

- Failure of important functions of the water treatment device.
- Danger to persons due to electrical and mechanical effects.
- Danger to persons and the environment due to leaks.

Refrain from any unsafe working methods.

Failure to comply with this instruction manual and the safety information can not only result in dangers for people but can also harm the environment and the unit. Improper use or failure to observe the instructions and warnings given in this manual will result in loss of warranty coverage.

1.3 Units used

In derogation of the International System of Units (SI = System International), the following units are used:

Units	Conversion
°F	°F = 9/5 °C + 32
bar	1 bar = 10 ⁵ Pa = 0,1 N/mm ²
G	1 G = 4,546 Liters
¾"	19.05 mm
1"	25.4 mm

2. Intended Use

Installation and use of the water treatment devices are each subject to the applicable national regulations.

Apart from instructions given in this manual, all laws and regulations governing installation, health & safety in the workplace and valid in the country of use must be adhered to at all times.

The water to be treated must comply with the European Drinking Water Directive!

Always contact the manufacturer/supplier before using water with a different quality or with additives!

This water treatment devices is suitable for use in cold drinking water up to maximum ambient temperature of 30 °C (86 °F).

It is produced according to the latest standards of technology and the generally accepted safety regulations in Germany.

The water treatment devices may only be used as described in the instruction manual. Any other operation or operation beyond the specified use, is not in accordance with the manufacturer's specifications and will result in a loss of warranty coverage.

Additional dangers exist in case of non-intended use and failure to observe the danger symbols and safety information. The manufacturer/supplier is not liable for any losses or damage resulting from this. The risk is solely borne by the user.

Intended use also includes observing the instruction manual.

The manufacturer/supplier must always be consulted before using the water treatment devices outside the use limitations given in the instruction manual.

The water treatment devices are only to be used in a technically perfect condition, for their intended use, safely and aware of the dangers and with full observance of the instruction manual!

Have any malfunctions corrected immediately!

In order to be able to safely discharge the wastewater in operation and in case of any defect in the system, precise compliance with the details stated in the chapter on "Requirements for the place of installation" is necessary!

2.1 Water pressure

The water pressure must be between 1.5 and 8 bar.

If the water treatment device is not regularly regenerated, this can result in pressure loss and impairment of the softening function.



(see chapter "Safety information and dangers due to non-compliance")

If the **water pressure is more than 8 bar** a pressure reducer must be installed **before** the water treatment device (see fig. 2). An operating pressure of more than 8 bar can lead to malfunction and failure.

The optimal operating pressure range for the water treatment device lies between 3 and 5 bar. It works most economically under these pressure conditions. In modern sanitary installations (in particular where single lever mixers are used), despite normal system pressure conditions, peak pressures of up to over 30 bar frequently occur. This can cause damage to important functional interior parts of the water treatment device.

2.2 Notes on special dangers

2.2.1 Electrical equipment / installa-

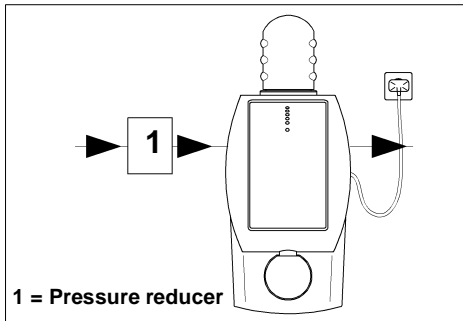

Fig. 2: Pressure reducer upstream of the water treatment device



For a **water pressure of 5 to 8 bar** we recommend the installation of a pressure reducer.

utions



There must not be any electrical cables and devices underneath or in the immediate vicinity of the water treatment device!

Electrical devices / equipment, which are not splash proof and which are located near the water treatment device can be damaged by water which escapes from the water treatment device during "Cleaning - Flushing" or improper use. If the electrical devices / installations are connected to the power supply, a short circuit can also occur with the risk electric shock. Electrical devices / equipment located near the water treatment device must therefore be splash proof and comply with the legal regulations for wet rooms (IP44). Please ensure that all safety guidelines connected with electrical work and valid in the country of use are adhered to at all times when working on this unit!

3. Product Information

3.1 Intended purpose

This water treatment device is suitable for use in cold drinking water up to a maximum water temperature of 30 °C (86 °F).



(see chapter "Safety information and dangers due to non-compliance")

Please refer to the chapter on "Intended Use" for use restrictions.

This water treatment device reduces the tendency of the water to precipitate out excess calcium and thus protects the water-pipes and water heaters from lime deposits.

Appliances and taps are protected.



Lime deposits restrain the water flow and can therefore lead to an increased energy consumption.

3.2 Test marks

DVGW mark



Fig. 3: Test marks

The units correspond to the technical regulations for drinking water installations in accordance with DIN 1988.

They fulfill the requirements of the DVGW¹⁾ (Deutsche Vereinigung des Gas- und Wasserfaches e.V. technical-scientific association) working sheet W 510 "Calcium-protection appliances for use in drinking water installations" (see fig. 3).

3.3 Materials used

The used materials are resistant to the physical, chemical and corrosive properties to be expected in the drinking water. All materials are hygienically and physiologically safe. Plastics fulfil the UBA (Umwelt Bundesamt / Federal Environmental Agency) KTW-Guideline and DVGW Working Sheet W270, and metallic materials fulfil the requirements of DIN 50930-6 (Impact on the Drinking Water Quality)

4. Installation

4.1 General



(see chapter "Safety information and dangers due to non-compliance")

The unit may only be installed by skilled personnel.

The chapter on "Intended Use" must always be observed !

The pipes must be able to support the water treatment device safely.

If not, mechanical damage or fractures/bursts can occur in the pipes. This can result in major water damage. People close to the water treatment device are exposed to a health risk due to the large quantities of water released. Therefore, if necessary, the pipes must be additionally fixed or supported.

Always observe the spacing given to ensure convenient operation and servicing
Mounting Dimensions

A distance of at least 150 mm above and below the water treatment device is required in order to be able to carry out properly all the maintenance and servicing work correctly.

When installing the water treatment devices in the feed-pipe to the water heater, ensure that the safety valve of the water heater is located **after** the water treatment device in the direction of flow.

1) DVGW: German Gas and Water Industry Association

4.2 Requirements for the place of installation



ATTENTION

(see chapter "Safety information and dangers due to non-compliance")

The room where the unit is installed must be dry and frost free!

Unauthorised persons must not have access to the water treatment device!



ATTENTION

(see chapter "Safety information and dangers due to non-compliance")

- The ambient temperature must not exceed 30 °C (86 °F)! Higher temperatures or exposure to direct sunlight may damage the material.
- We recommend that the water treatment devices is installed after a backwash protective filter, to prevent particles of dirt and sand being swept in.



A power connection (230 V, 50 Hz), which has to be permanently under voltage, must be available*.

- Length of the power lead is approximately 1.5 m.
- Especially where using small cross-sections and soft pipe materials, the water pipes should be supported in the vicinity of the connecting flange with two pipe-clamps.

4.2.1 Installing position



ATTENTION

(see chapter "Safety information and dangers due to non-compliance")

Always install the water treatment devices in a vertical position ($\pm 5^\circ$)!

* also available in 110V / 60 Hz. version where required.

Failure to do so may result in impairments to the unit's function.

4.2.2 Power supply



A splash proof socket is required for the power supply, in accordance with the legal regulations for wet rooms.



ATTENTION



(see chapter "Safety information and dangers due to non-compliance")

A permanent power supply must be available. If the water treatment devices is not permanently supplied with power, there is no warning in case of faults, and no water is treated. Please ensure that all safety guidelines connected with electrical work and valid in the country of use are adhered to at all times when working on this unit!

4.2.3 Mounting the built-in rotary flange

The built-in rotary flange is used as a connecting element between the pipe and the water treatment device.

It is suitable for both, -horizontally and vertically mounted pipes.

The built-in rotary flange must be installed in the direction of flow. This is marked by a cast in arrow (see fig. 1).

Failure to observe these instructions will result in unit malfunction!



ATTENTION



(see chapter "Safety information and dangers due to non-compliance")

The flange surface of the built-in rotary flange must be in a vertical position! The built-in rotary flange must be fitted free of mechanical stress. Failure to do so may result in damage and flooding!

In this case, people close to the water treatment devices are exposed to a health risk due to the large quantities of water.

Therefore, when mounting, ensure that no large forces act on the pipe, built-in rotary flange and water treatment devices.

4.2.4 Fitting the wall support

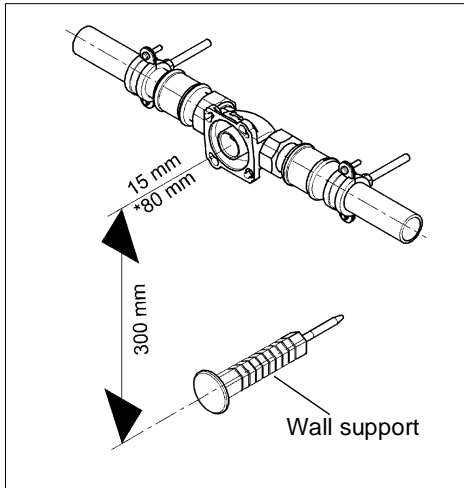

Fig. 4: Wall support without bypass valve

4.2.5 Mounting of the Water Treatment Device

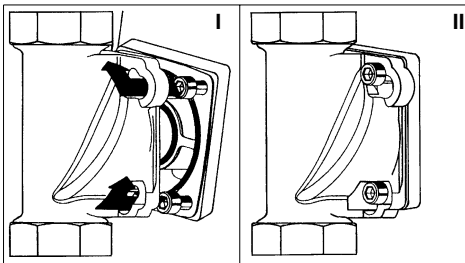

Fig. 5: Built-in rotary flange with bayonet fixture

After flushing the water pipe, remove the assembly lid of the built-in rotary flange.

Remove the white protective disc on the connecting flange of the water treatment devices by unscrewing the four M6 Allen screws.

Do not open the screws completely due to bayonet connection!

Lift up the water treatment devices and swivel it approx. 30° in an anti-clockwise direction. Position it on the built-in rotary flange so that the screw heads pass through the bayonet fixing drill holes (see fig. 5 I). Swivel the water treatment devices approx. 30° back in a clockwise direction and tighten the four hexagon socket screws (see fig. 5 II).

Nm Select the torque (approx. 4 Nm) so that the gasket locks and the water treatment device is not damaged or strained!

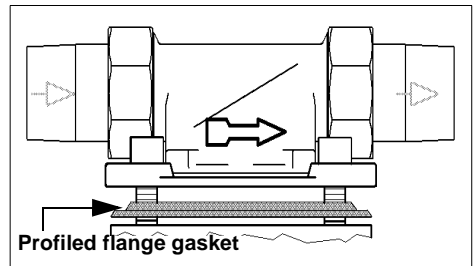

Fig. 6: Built-in rotary flange

The profile of the profiled flange gasket must point towards the built-in rotary flange. Failure to observe this can lead to leaks and water escaping. This can cause damage due to water to the house and its installations (see fig. 6). Please ensure that all regulations and guidelines connected with plumbing & safety in the workplace and valid in the country of use are adhered to at all times when working on this unit!

4.3 Examples for installing the water treatment devices

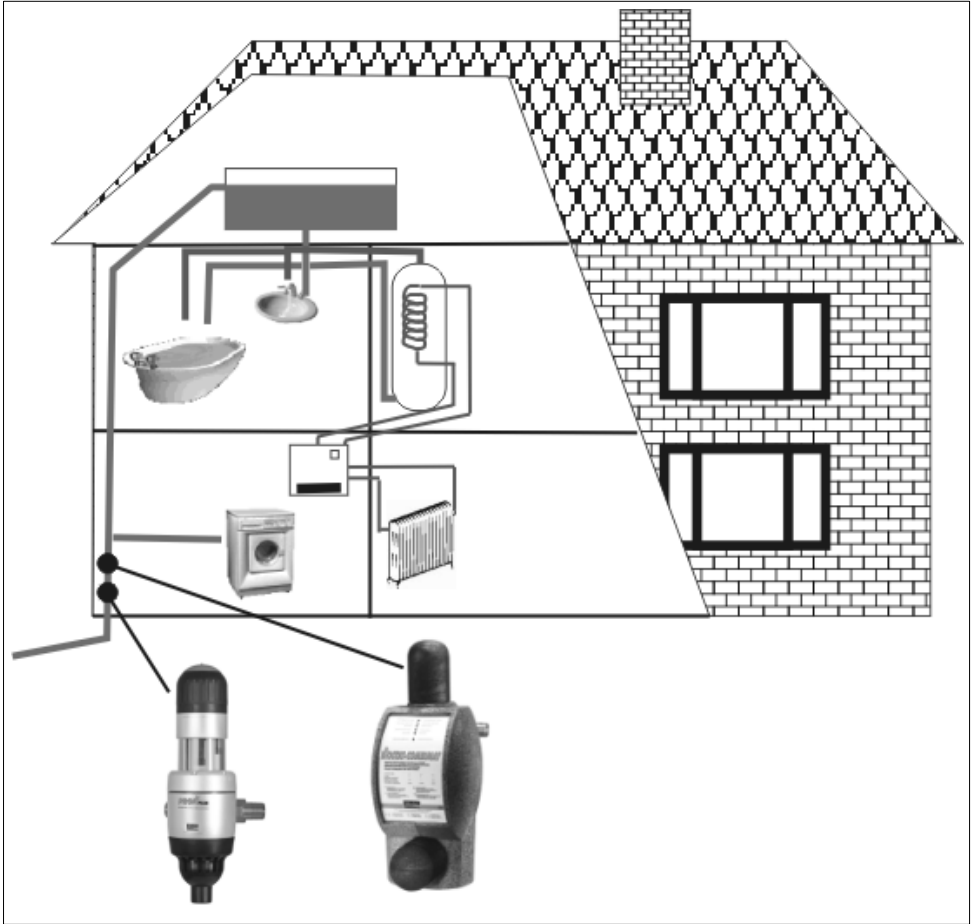

Fig. 7: A typical combi system with open vented hot water storage tank

4.4 Flush Discharge

An adequately dimensioned wastewater connection (e.g. floor drain) in accordance with local plumbing guidelines must be available for the flushing water.

The dimensioning depends on the actual conditions on site (e.g. wastewater pipe gradient, number of pipe bends, length of the waste-water pipe, etc.). Drains should be sized to ensure that all wastewater can be discharged adequately and safely, e.g. DN50.

If it is not possible to locate a drain connection directly under the water treatment devices, the wastewater hose can be routed over the water treatment device.

The wastewater hose for the flushing water must be led to the drainage channel without any kinks.

In all options, a free discharge must be ensured in accordance with local plumbing guidelines.

The loose end of the hose has to be firmly fixed with the included adhesive tape at the pipe or a similar object.

The flushing water must be discharged into a firmly mounted drain.



Ensure that the wastewater connection functions before plugging the power supply unit into the socket.

Flushing water discharge options

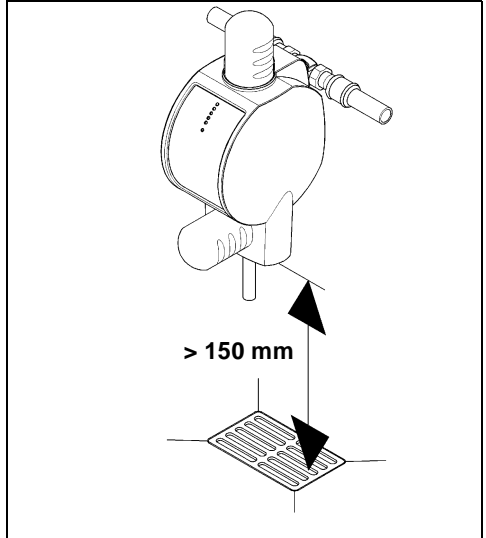
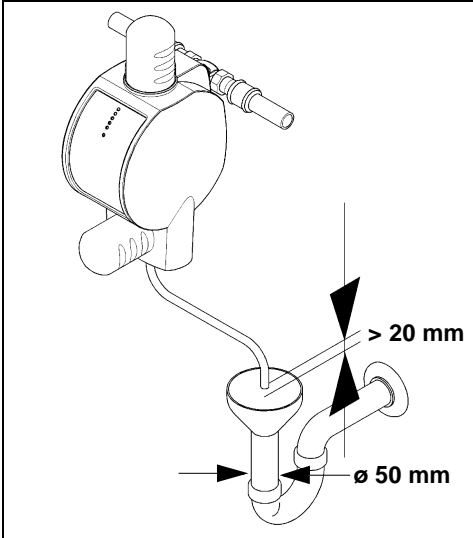

Fig. 8: Flushing water discharge options

5. Operation



ATTENTION

(see chapter "Safety information and dangers due to non-compliance")

Always observe the chapter on "Intended Use"!

5.1 Commissioning

For safety reasons, the water treatment devices must be **vented immediately** upon connection to the water supply. Set the bypass valve supplied at the setting "Betrieb" ("Operation") (see chapter "Mounting of the Bypass Valve (not in scope of delivery)").

- Turn on a water tap mounted after the water treatment devices.
- The power supply must be freely accessible.



Connect the water treatment device to the power supply. Plug the power supply into the socket.

- After the power supply has been connected, the electrical circuit performs a self-check of all the functions and parameters stored in the electronics.
- Following a successful check, all control lamps light up for 2 seconds (see chapter "Control lamps, manual push-buttons").
- As soon as LED 1 shows a continuous green light indicating "Betrieb" ("i.e. Operation"), the water treatment devices is ready for use. When water is flowing, the green LED 1 flashes (see chapter "Control lamps, manual pushbuttons").

Electrical circuit

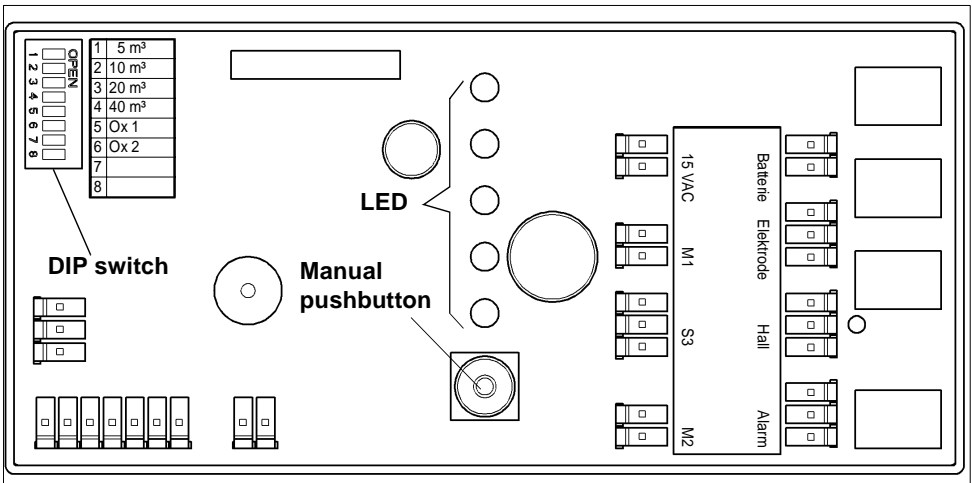

Fig. 9: Electrical circuit

5.2 Description of its function

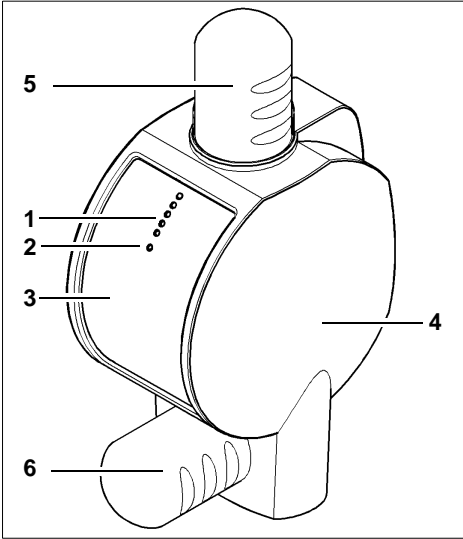

Fig. 10: BST-CA

- 1 Control lamps
- 2 Manual pushbutton
- 3 Type Plate
- 4 Panelling
- 5 Cleaning motor
- 6 Flushing motor

5.2.1 Treatment effect

The water treatment device works completely automatically. The treatment effect reached depends on actual flow rate. A flow-controlled water meter is integrated in the unit intake.

As water flows through the unit, a magnet in the water meter sends impulses to a hall sensor in the electronics enabling the system to calculate flow rate and regulate the treatment current to actual levels required offering optimal treatment for actual flow rates & water quality levels.

As soon as water flows, the water treatment is indicated by the flashing of green LED 1 (see fig. 12).

It is recommended that unit be switched of a period of 1-2 minutes when used in connection with high volume consumption. This is to optimize unit efficiency (optimal crystal formation).

5.2.2 Lime protection function

During treatment, the system sets free minute lime crystals (seed crystals) which attract lime dissolved in the water. The unit itself contains a titanium anode and a stainless steel brush which acts as a cathode. As soon as water flows through the unit, a current is passed between these two attracting dissolved lime to settle on the brush in the form of calcium carbonate crystals. During cleaning, the brush rotates shedding these micro-crystals. Larger crystals and particles sink to the unit floor during cleaning and are flushed out of the unit.

The lime particles can be seen in the flushing water as very fine "sand". The micro-crystals released during cleaning remain in the water supply and act as seed crystals attracting further dissolved lime to precipitate. In warm water applications, the growth of these crystals appears in the form of a gradual clouding in the water supply. In cold water applications this growth is much slower. The micro-crystals in both applications, however, remain light enough to remain in suspension and are passed through the system with the regular water flow. As calcium in the incoming water supply is now bound in the incoming water supply in the form of micro-crystals, it is still present, but cannot precipitate out onto other surfaces (pipes, heating elements, etc.) and these will no longer suffer from build-up or fur.

The flow-control water meter located in the unit inflow can monitor flow rates as low as 1.5 ltr./min. and, thanks to well coordinated electronic systems, offers optimal water treatment from low flow rates up to the nominal flow level adapting impulse generation to suit actual water quality conditions.

5.2.3 Hygiene unit

In addition to its lime-protection function, the water treatment device also combats bacterial build-up which can lead to sickness such as legionnaire's disease. This is achieved by means of the proven anodic oxidation method.

The hygiene unit in the water treatment devices consists of an electrode specially coated with a mixture of oxides of precious metals as an additional anode and an electronic control unit. The approved circular stainless steel brush is used here, too in the hygiene unit as a deposition cathode in addition to its function as a lime protection. The cathode brush is freed of lime deposits from time to time by means of a scraper, so that a pole reversal of the electrodes is not necessary for the cleaning off. Avoiding regular pole reversal ensures the working life of the electrodes is kept at maximum.

As soon as the water is flowing, a small voltage is applied to the water itself thus producing oxidants which combat bacteria without the need for additional chemical additives. Although this treatment does create an environment hostile to bacterial growth, it will not provide complete protection in water with a high bacterial content. Where this is the case, additional disinfection measures should be taken in accordance with regulations valid in the country of use in order to ensure the water supplied is bacteria-free.

The disinfection used in this unit is not intended as a full disinfection in the standard sense, but as a prophylactic measure designed to combat bacterial build up within the unit itself.

5.3 Control lamps, manual pushbuttons

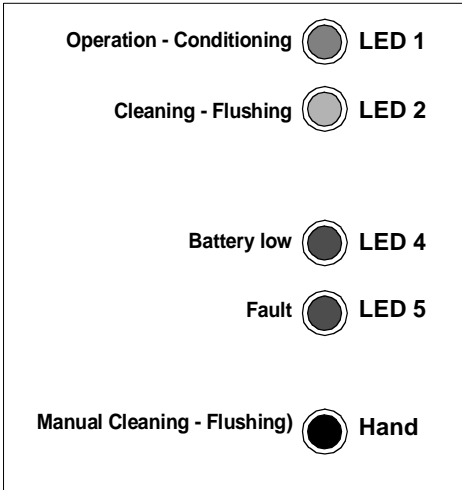

Fig. 11: Control lamps, manual pushbuttons

LED 1	Operation - Conditioning
--------------	---------------------------------

Permanent green light: the water treatment device is ready for use.

Green light flashing: water treatment is in operation.

LED 2	Cleaning - Flushing
--------------	----------------------------

Permanent green light: a cleaning - flushing is in operation.

LED 4	Battery low
--------------	--------------------

Red light flashing: the battery must be changed otherwise no further Cleaning - Flushing can be carried out.

LED 5	Fault
--------------	--------------



Red flashing light: the water treatment device is not ready for use (see chapter "Fault").

Hand	manual pushbutton
-------------	--------------------------

Triggers Cleaning - Flushing.

5.4 Cleaning - Flushing

Depending on the quality of the water and the operating methods, a thin coating of lime is formed on the brush in the treatment chamber. This lime layer must be removed and flushed out of the water treatment devices at regular intervals.

The water treatment device has a unit to clean the brush and a flush valve for rinsing out the lime particles.

i If the flushing is not carried out, the electrolysis will be switched off automatically and, in order to protect the treatment chamber, water will no longer be treated. After having carried out the "Cleaning - Flushing" procedure, the water treatment appliance is immediately ready for use again.

Cleaning and flushing is carried out automatically by two electric motors.



Make sure that the drain connection is functional before plugging the power supply into the socket (see chapter "Discharging the flushing water").

During Cleaning - Flushing, the yellow LED 2 lights up.

Die LED 2 can be started manually by operating the manual pushbutton.

5.5 Warning message "Battery flat"

To ensure that Cleaning - Flushing is carried out completely, even in case of a power failure, the water treatment appliance has a 9V block battery installed as an emergency power supply.

Before each Cleaning - Flushing, a battery test will be carried out. A missing, unloaded or defective battery is indicated by the flashing of the red LED 4. No cleaning cycle is possible then.

5.6 Mounting of the covers

Dismantling:



Disconnect the power supply from the socket.

- Withdraw the upper / inferior clamping fixture.
- Carefully pull apart the right and the left panel parts by the handle cavities on the back of the covers.
- Remove the type plate and the covers.

Assembly:

- Push the right and left parts of the paneling together till a gap of approximately 15 mm is left.
- Ensure that the cable is not trapped!
- Refit the type plate in the blanks, of the covers, situated above and below.
- Push the covers completely together.



Plug the power supply into the socket!

5.7 Replacing the batteries

When a change of batteries is necessary (LED 4 flashes) the following procedure is adopted:



Disconnect the power supply from the socket.

- Remove the covers from the water treatment devices.
- The battery is located behind the electrical switch and must be disconnected from the battery clip.
- Exchange the battery and push it back into the corresponding blank behind the switch.
- Remount the covers on the water treatment devices.



Plug the power supply into the socket!

- Return run-down batteries to a distributor or to a properly- authorised local disposal return point.



Only use 9 V alkaline type block batteries - see battery description.

5.8 Modifications / changes / spare parts



ATTENTION



(see chapter "Safety information and dangers due to non-compliance")

Only original spare parts are to be used!

For safety reasons, it is forbidden to carry out unauthorized modifications on this unit! These may not only impair the function of the unit itself, but also lead to leaks and bursting!

The test marks imprinted on the unit are only valid if original spare parts are used.

5.9 Stoppages



(see chapter “Safety information and dangers due to non-compliance”)

If a water treatment device has to be removed from the flange or unscrewed, the chapter on “Intended Use” must always be observed!

- Protect the flange surfaces from damage! Damaged flange surfaces cannot close tight. As a result, escaping water can damage the building and installations.
- Ensure that no dirt can get into the water treatment device! This dirt can get into contact with and be discharged into the drinking water when the water treatment device is switched back on. The health of people who drink dirty water is at risk.
- Store the water treatment device in a frost-free environment! Frost can cause any water contained in the water treatment device voids to freeze and thus cause mechanical damage to the water treatment device so that it leaks at operating pressure or can burst. Leaking water can cause major damage to the building. In addition, people near the water treatment device can be injured by breaking off water treatment device parts.
- When restarting the water treatment device, follow the instructions for a new water treatment device.

6. Fault

The opening of the units, and the exchange from parts that are water pressure-charged must be carried out by qualified personnel only!



If a fault occurs at the unit, it will be indicated by the LED 5 flashing red.

Deleting the error message:



Disconnect the power supply from the socket. Plug it back in after approx. 5 seconds!

Help with faults:

Fault	Cause	Remedy
Permanent red light from LED 5 and permanent acoustic signal.	DIP switch incorrectly set.	Reset DIP switch (see chapter "Setting of the cleaning interval").
LED 5 flashes red.	Momentary power failure.	Delete the failure message. The appliance reverts automatically to normal operation.
	Cable connections have become loose.	 <p>Disconnect the power supply from the socket!</p> <ul style="list-style-type: none"> – Remove the covers (see chapter "Mounting of the covers"). – Check the cable connections, reconnecting each plug-and-socket connection which is loose. – Remount the covers. – Plug the power supply back into the socket.
Repeated fault message after having re-plugged the power supply in the socket.		<p>Inform fitter or nearest available customer service point without any delay.</p> <p>Quote the appliance number. See appliance number in front of the chapter entitled "About this Operating Instructions".</p>  <p>Disconnect the power supply from the socket!</p> <p>The water treatment device must remain switched off until the arrival of the customer service. Set the bypass valve to "Bypass".</p> <p>If there is no bypass valve mounted, ensure that there is not any water escaping from the waste water connection.</p> <p>Remove the ball-valve actuator with a sudden pull. Close the ball-valve with the hand lever included.</p>
LED 4 flashes red.	The battery is empty.	Replace by a new battery (type alkaline). Return run-down batteries to the collection points.

7. Maintenance



(see chapter "Safety information and dangers due to non-compliance")

Always observe the chapter on "Intended Use"!

7.1 Cleaning



(see chapter "Safety information and dangers due to non-compliance")

Only use clear, clean drinking water to clean the housing.

Domestic all-purpose cleaners and glass cleaners can contain up to 25% solvents or alcohol (spirits).

These substances can chemically attack the plastic parts, which can lead to brittleness or even fractures.

Such cleaners must therefore not be used.

8. Warranty and Services

All JUDO products are supplied under the legal warranty requirements valid in the country of use.

Warranty is only valid in cases where the unit supplied has been used for the purposes and under the conditions stipulated in this manual. Neither JUDO nor the distributor can accept liability in any form for damage to persons, property or the environment cause by or during the installation and operation of this unit for purposes other than those described herein.

In order to maintain a high level of operational performance of your unit, JUDO strongly recommends you close a maintenance contract with an authorised service agent near you.

9. Data Sheet

9.1 Type

JUDO BIOSTAT-COMBIMAT
water treatment device

Abbreviated name: BST-CA

9.2 Models

Model	Size	Order No.
BST-CA Type 15	¾"	8210416
BST-CA Type 25	1"	8210417

9.3 Technical specifications

- Maximum ambient temperature and water temperature: 30 °C (86 °F).
- **The water to be treated must comply with the European Drinking Water Directive!**
- Threaded connection according to DIN 2999. For nominal pressures greater than 10 bar use a pressure reducer.

Operating pressure	Nominal pressure
1.5 - 8 bar	PN 10

The nominal pressure signifies the pressure step, according to that the water treatment device must fulfil the requirements according to W 510. The maximum operating pressure is lower, in order to ensure the optimal function of the water treatment device.

BST-CA	Type 15	Type 25
Nominal flow rate	1.5 m ³ /h	2.5 m ³ /h
Pressure loss at nominal flow rate	0.4 bar	0.4 bar
Pipe connection	19.05 mm	25.4 mm
Max. power consumption	25W	25W
Electrical connection	230 V / 50 Hz	230 V / 50 Hz
Application	One-family house	One- or two-family house
Average daily water consumption max. 500 liters	max. 500 Liters	max. 800 Liters

Installation height depends on the type of drainage (see chapter "Discharging the flushing water").

9.4 Mounting Dimensions

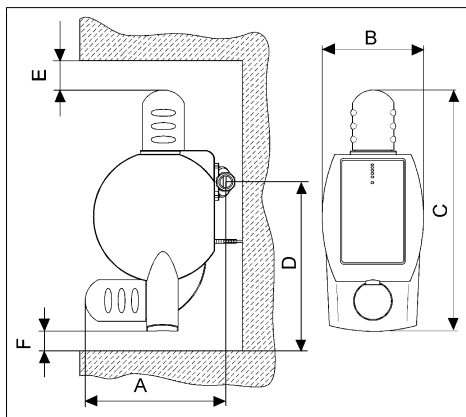

Fig. 12: Mounting Dimensions example BST-CA

Dimensions

A	Depth to pipe centre	320
B	Width	230
C	Height	550
D	Minimum height to pipe	475
E	Minimum distance above	150
F	Minimum distance below	150

All dimensions in [mm] (see fig. 12)

9.5 Scope of supply

- Water treatment devices
- Wall support (2200500) to prevent the water treatment appliance from twisting. No support of weight!
- Built-in rotary flange JQE with clamp fitting
- Installation and Operating Instructions

9.6 Accessories (not included in scope of supply)

- Bypass valve JQX, Order No. 8735210
- Extension QUICKSET JQR for series connection of two JUDO units (e.g. filter and water treatment device) to a built-in rotary flange, Order No. 8250041

10. Spare Parts BIostat-COMBIMAT

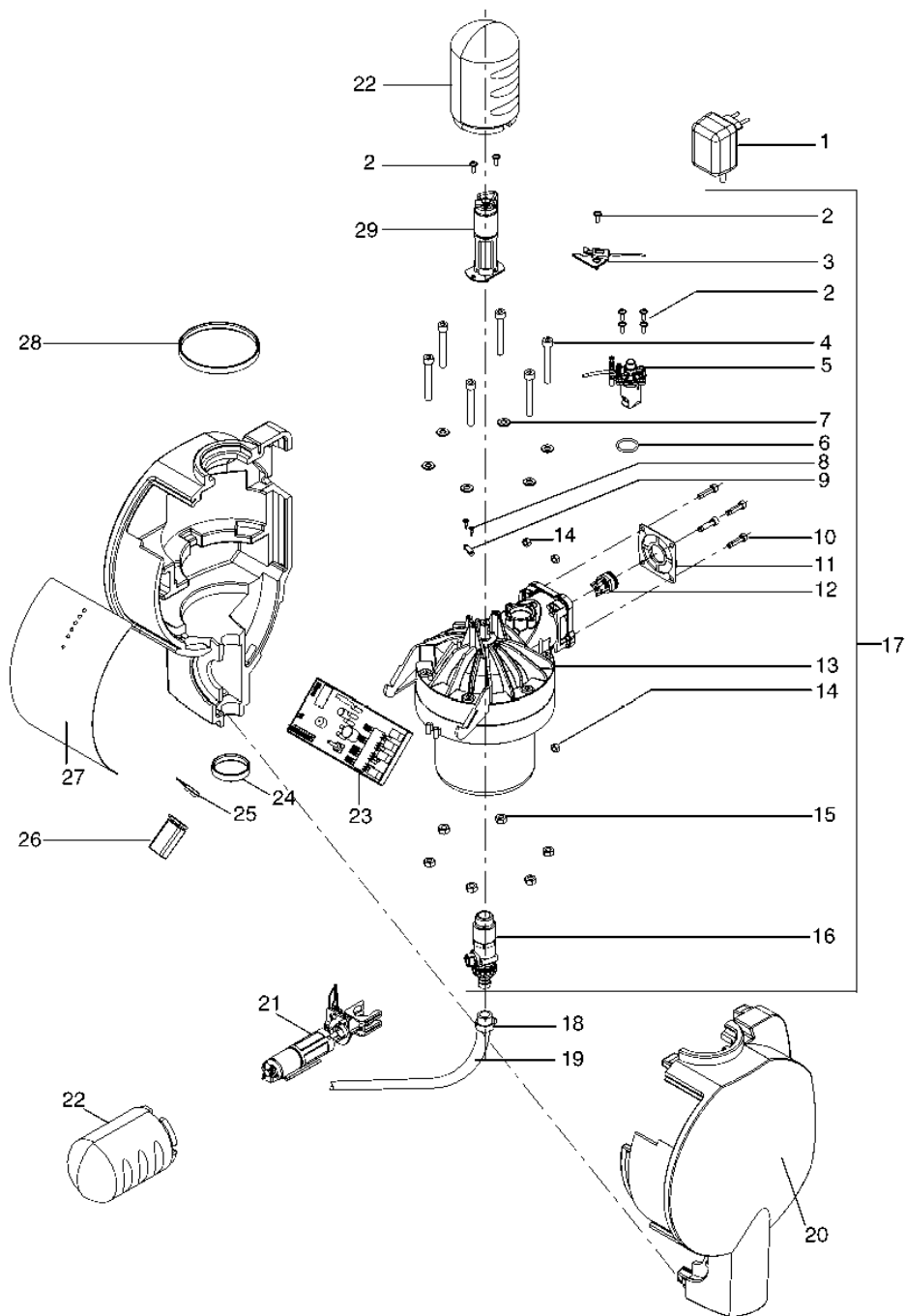

List of Spare Parts BIostat-COMBIMAT

Item	Description (Recommended average replacement interval for wearing part [*])	piece	Order No.	AU ¹ /piece
1	Power supply complete	1	2210419	85
2	EJOT- screw	7	1650201	3
3	Spare parts kit for sliding contact	1	2210447	70
4	Cheese head screw M8x65	6	1650365	3
5	Water meter - insert ****	1	2210292	45
6	O-ring 21.89x2.62 ****	1	1200125	1
7	Disc A8.4	6	1607125	1
8	Screw 2.9x13	2	1609172	1
9	Strain relieving bracket	1	1609114	2
10	Cheese head screw M6x25	4	2010199	2
11	Profiled flange seal **	1	1200218	5
12	Backflow preventer 1"	1	1610287	29
13	Spare parts kit for basic unit	1	2210448	694
14	Hexagonal nut M6	4	1633145	1
15	Hexagonal nut M8	6	1607117	2
16	Spare parts kit for rinsing hose connection	1	2210449	34
17	Basic unit complete	1	2210450	1147
18	Hose clamp	1	1633344	7
19	Hose to drain	1	2633342	17
20	Covers	1	1140103	72
21	Spare parts set for flushing motor	1	2210445	317
22	Engine cowling	2	1140101	27
23	Electric circuit Type 15	1	2210325	580
23	Electric circuit Type 25	1	2210326	640
24	Guard Ring small	1	1120624	4
25	Battery cable	1	2210286	11

Item	Description (Recommended average replacement interval for wearing part [**])	piece	Order No.	AU¹⁾/piece
26	E-block-battery 9V	1	1500261	18
27	Front foil	1	1702028	38
28	Guard Ring large	1	1120625	5
29	Brush drive complete	1	2210348	265

1) AU = Accounting unit

Replacement interval: ** = 2 years, *** = 3 years, **** = 4 years

11. Customer Support



JUDO UK Limited

The old court House

Ascot, SL5 7EN

Phone: (44) 700 605 9441

E-Mail: info@judo.eu

Internet: www.judo.uk.com

Installed by:

Please contact your local distributor for details of a service agent near you.

1702022 • 2009/08