

Gentle on water, strong against limescale

POWER TOWER BIOSTAT 2000

Limescale Protection System

JUDO BIOSTAT series anti-limescale systems stop limescale deposits in domestic water systems. Drinking water remains drinking water. Nothing is added to or removed from your water.

The advantages

- ◆ DVGW tested
- ◆ No additives, no salts
- ◆ No cartridges to replace
- ◆ Stops limescale deposits in water pipes and hot water heaters (up to 80°C)
- ◆ Extends the service life of your domestic appliances
- ◆ Rinsing function for larger quantities of limescale residue
- ◆ Multifunctional display (type 25 E/type 50 E)
- ◆ Made in Germany

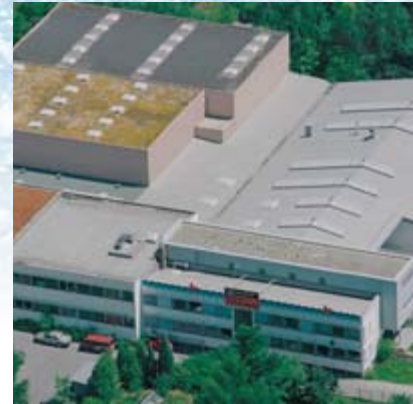



The problem

Tap water contains calcium. When it is heated the calcium is deposited as limescale. This leads to long heating times, increased energy consumption and expensive repairs.

The solution: BIOSTAT 2000 from JUDO.

The BIOSTAT 2000 automatically adjusts to any drinking water. Its innovative technology reduces the water's tendency to deposit limescale. Yet unlike other methods the BIOSTAT does not affect the property of the water, instead it balances it out. The lime remains there where it is useful to you: as dissolved calcium in drinking water.



Type 50E

For each home

For each household, for each house: the BIOSTAT 2000 is available in various sizes and can be extended to any required performance class. Ideal for subsequent installation too.

POWER TOWER BIOSTAT 2000

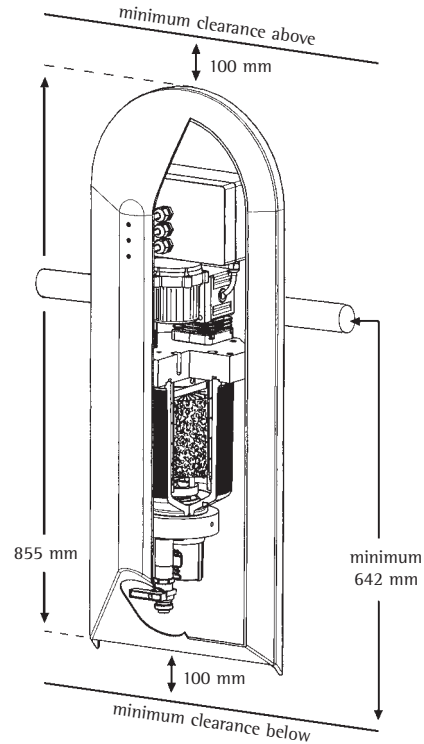

Technical specifications

Model BST 2000	Type 15	Type 25E	Type 50E*
Multifunctional display	-	•	•
Pipe connection	3/4"	1"	1 1/2"
Nominal flow rate m ³ /h	1.5	2.5	5
Pressure loss at nominal flow rate bar	0.2	0.4	0.5
Max. inlet water temperature °C	30	30	30
Max. Power consumption Watt**	100	120	240
Installed length mm	180	195	252
Width mm	330	330	520
Height mm	855	855	855
Depth to pipe centre mm	240	243	-
Depth to pipe centre with JQX mm	305	308	340
Order No.	8210300	8210310	8210311

• standard equipment

*incl. JQT for tandem connection of 2 BST 25 E and 2 single lever bypass valves JQX

**only while the water is extracted

Fast installation

With the JUDO Quickset-E your fitter can carry out the installation fast and cleanly.



JUDO Quickset-E

We stock JUDO equipment:



JUDO Wasseraufbereitung GmbH
Postfach 380 · D-71351 Winnenden
Tel. +49 (0) 71 95/6 92-0
Fax +49 (0) 71 95/6 92-110
e-mail: export@judo-online.de
www.judo-online.de